

---

# Service Guide

Publication number 16740-97000  
December 2001

For Safety information, Warranties, and Regulatory information, see the pages at the end of the book.

© Copyright Agilent Technologies 2001  
All Rights Reserved.

---

## Agilent Technologies 16740/41/42A Logic Analyzer

---

## The Agilent 16740/41/42A Logic Analyzer—At a Glance

The Agilent Technologies 16740/41/42A are 400-MHz state/800-MHz timing logic analyzer modules for the Agilent Technologies 16700-series logic analysis system. The 16740/41/42A offer high performance measurement capability.

### Features

Some of the main features of the 16740/41/42A are as follows:

- 64 data channels
- 4 clock/data channels
- 1Mb memory depth per channel (16740A)
- 4Mb memory depth per channel (16741A)
- 16Mb memory depth per channel (16742A)
- 200-MHz maximum state acquisition speed
- 800-MHz maximum timing acquisition speed
- 400-MHz conventional timing analysis
- 2-GHz timing zoom
- Expandable to 340 channels

### Service Strategy

The service strategy for this instrument is the replacement of defective assemblies. This service guide contains information for finding a defective assembly by testing and servicing the 16740/41/42A state and timing analyzer module.

The modules can be returned to Agilent Technologies for all service work, including troubleshooting. Contact your nearest Agilent Technologies Sales Office for more details.

### Application

This service guide applies to an 16740/41/42A module installed in the 16700-series logic analysis system mainframes.

The 16740/41/42A uses operating system version A.02.50.00 or higher. Agilent Technologies 16700-series mainframes with serial number prefix lower than US4148 are factory-installed with older operating system versions. If your mainframe operating system is older than the required version, contact your Agilent Technologies Service Center for newer software before attempting the performance verification procedures in chapter 3.

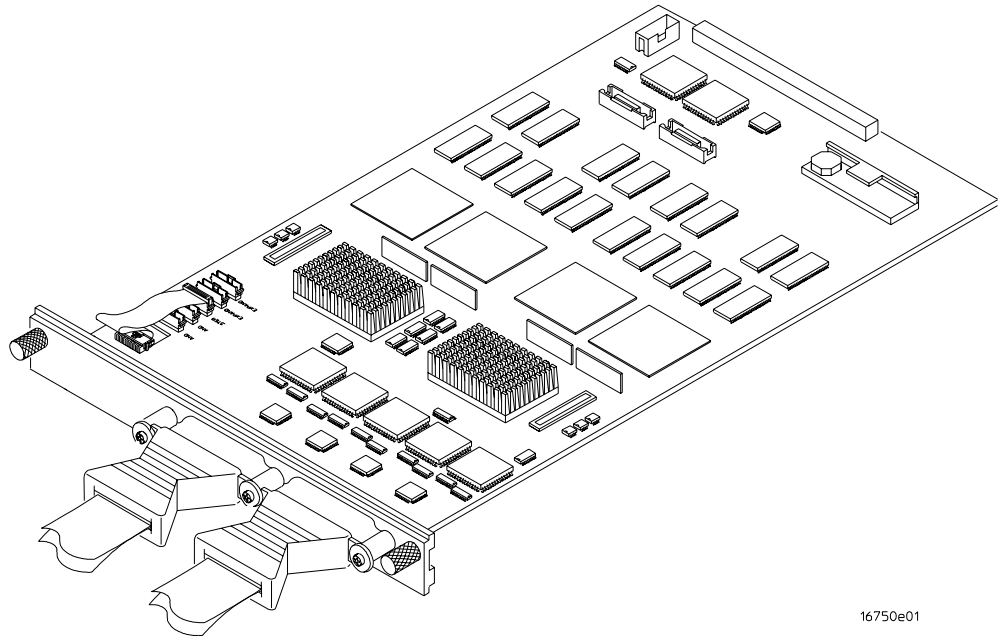

16750e01

### **The 16740/41/42A Logic Analyzer**

---

## In This Book

This book is the service guide for the 16740/41/42A 200-MHz state/800-MHz timing logic analyzer modules.

This service guide has eight chapters.

Chapter 1 contains information about the module and includes accessories for the module, specifications and characteristics of the module, and a list of the equipment required for servicing the module.

Chapter 2 tells how to prepare the module for use.

Chapter 3 gives instructions on how to test the performance of the module.

Chapter 4 contains calibration instructions for the module.

Chapter 5 contains self-tests and flowcharts for troubleshooting the module.

Chapter 6 tells how to replace the module and assemblies of the module and how to return them to Agilent Technologies.

Chapter 7 lists replaceable parts, shows an exploded view, and gives ordering information.

Chapter 8 explains how the analyzer works and what the self-tests are checking.

## **1 General Information**

Accessories	10
Mainframe and Operating System	10
Specifications	11
Characteristics	12
Environmental Characteristics	12
Recommended Test Equipment	13

## **2 Preparing for Use**

Power Requirements	16
Operating Environment	16
Storage	16
To inspect the module	16
To prepare the mainframe	17
To configure a one-card module	18
To configure a multi-card module	20
To install the module	26
To turn on the system	28
To test the module	28
To clean the module	29

## **3 Testing Performance**

To Perform the Self-tests	33
Perform the power-up tests	33
Perform the self-tests	34
To Set Up the Test Connectors	35
To Set up the Test Equipment and the Analyzer	38
Set up the equipment	38
To Test the Threshold Accuracy	40
Set up the equipment	40
Set up the logic analyzer	41
Connect the logic analyzer	42
Test the ECL threshold	43
Test the 0 V User threshold	46
Test the next pod	47

---

## Contents

To Test the Single-clock, Single-edge, State Acquisition	48
Set up the equipment	48
Set up the logic analyzer	48
Connect the logic analyzer	53
Verify the test signal	56
Check the setup/hold combination	58
To Test the Multiple-clock, Multiple-edge, State Acquisition	66
Set up the equipment	66
Set up the logic analyzer	67
Connect the logic analyzer	71
Verify the test signal	74
Check the setup/hold with single clock edges, multiple clocks	76
To Test the Single-clock, Multiple-edge, State Acquisition	83
Set up the equipment	83
Set up the logic analyzer	84
Connect the logic analyzer	88
Verify the test signal	91
Check the setup/hold with single clock, multiple clock edges	93
To Test the Time Interval Accuracy	98
Set up the equipment	98
Set up the logic analyzer	99
Connect the logic analyzer	102
Acquire the data	102
To Test the Multi-Card Module	105
Set up the equipment	105
Set up the logic analyzer	106
Connect the logic analyzer	110
Verify the test signal	113
Check the setup/hold combination	115
Performance Test Record	121
<b>4 Calibrating</b>	
Calibration Strategy	126

## **5 Troubleshooting**

- To use the flowcharts 128
- To run the self-tests 131
- To exit the test system 132
- To test the cables 133
- To test the auxiliary power 138

## **6 Replacing Assemblies**

- Tools Required 140
- To remove the module 140
- To replace the circuit board 142
- To replace the module 143
- To replace the probe cable 144
- To return assemblies 145

## **7 Replaceable Parts**

- Replaceable Parts Ordering 148
- Replaceable Parts List 149
- Exploded View 151

## **8 Theory of Operation**

- Block-Level Theory 154
- Self-Tests Description 158





---

## General Information

This chapter lists the accessories, the specifications and characteristics, and the recommended test equipment.

---

## Accessories

The following accessories are supplied with the 16740/41/42A logic analyzer.

<b>Accessories Supplied</b>	<b>Agilent Part Number</b>
Probe Tip Assembly, Qty 4	01650-61608
Grabbers, Qty 4 packages	5090-4356
Extra Probe Leads, Qty 1 package	5959-9333
Extra Probe Grounds, Qty 4 packages	5959-9334
Probe Cable and Pod Labels, Qty 1	01650-94312

---

## Mainframe and Operating System

The 16740/41/42A logic analyzer requires an Agilent Technologies 16700-series logic analysis system with operating system version A.02.50.00 or higher.

---

**NOTE:**

Earlier versions of the 16700A/01A/02A mainframe contained only two cooling fans and might not provide adequate cooling to ensure reliable performance. If the first six digits of the 16700A/02A serial number (located on the back of the instrument) are US3849 or higher, or the first six digits of the 16701A are US3902 or higher, the instrument is a three-fan model, and there is sufficient cooling.

---

---

## Specifications

The specifications are the performance standards against which the product is tested.

Threshold Accuracy	$\pm (65 \text{ mV} + 1.5\% \text{ of threshold setting})$
Maximum State Speed (all clock schemes)	200 MHz
Minimum Master-to-Master Clock Time *	5.000 ns

### **Setup/Hold Time for Different Clock Schemes: \***

Single Clock, Single Edge:	4.5/-2.0 ns through -2.0/4.5 ns, adjustable in 100-ps increments
Single Clock, Multiple Edges:	5.0/-2.0 ns through -1.5/4.5 ns, adjustable in 100-ps increments
Multiple Clocks, Multiple Edges:	5.0/-2.0 ns through -1.5/4.5 ns, adjustable in 100-ps increments

\*Specified for an input signal  $V_H = -0.9 \text{ V}$ ,  $V_L = -1.7 \text{ V}$ , threshold =  $-1.3 \text{ V}$ , and slew rate =  $1 \text{ V/ns}$ .

---

## Characteristics

The characteristics are not specifications, but are included as additional information.

	<b>Full Channel</b>	<b>Half Channel *</b>
Maximum State Clock Rate	200 MHz	Not applicable
Maximum Conventional Timing Rate	400 MHz	800 MHz
Channel Count per Card	68	34
Channel Count per Three-Card Module	204	102
Channel Count per Five-Card Module	340	170
Memory Depth (16740A)	1M	2M
Memory Depth (16741A)	4M	8M
Memory Depth (16742A)	16M	32M

\* Half channel mode is only available for timing analysis.

---

## Environmental Characteristics



### Probes

Maximum Input Voltage  $\pm 40$  V, CAT I, CAT I = Category I, secondary power line isolated circuits.

### Auxiliary Power

Power Through Cables 1/3 amp at 5 V maximum per cable.

### Operating Environment

Temperature Instrument, 0 °C to 55 °C (+32 °F to 131 °F).  
Probe lead sets and cables, 0 °C to 65 °C (+32 °F to 149 °F).

Humidity Instrument, probe lead sets, and cables, up to 95% relative humidity at +40 °C (+122 °F).

Altitude To 4600 m (15,000 ft).

Vibration Operating: Random vibration 5 to 500 Hz, 10 minutes per axis,  $\approx 0.3$  g (rms).  
Non-operating: Random vibration 5 to 500 Hz, 10 minutes per axis,  $\approx 2.41$  g (rms); and swept sine resonant search, 5 to 500 Hz, 0.75 g (0-peak), 5 minute resonant dwell at 4 resonances per axis.

Operating power supplied by mainframe.

Indoor use only.

Pollution Degree 2.

---

## Recommended Test Equipment

### Equipment Required

Equipment	Critical Specifications	Recommended HP/ Agilent Model/Part	Use *
Pulse Generator	200 MHz, 2.5 ns pulse width, < 600 ps rise time	8133A Option 003	P, T
Digitizing Oscilloscope	≥ 6 GHz bandwidth, < 58 ps rise time	54750A mainframe with 54751A plug-in module	P
Function Generator	Accuracy $\leq (5)(10^{-6}) \times$ frequency, DC offset voltage $\pm 1.5$ V	3325B Option 002	P
Digital Multimeter	0.1 mV resolution, 0.005% accuracy	3458A	P
BNC-Banana Cable		11001-60001	P
BNC Tee	BNC (m)(f)(f)	1250-0781	P
Cable	BNC (m-m) 48 inch	10503A	P
SMA Coax Cable (Qty 3)	≥ 18 GHz bandwidth	8120-4948	P
BNC Coax Cable	BNC (m-m), > 2 GHz bandwidth	8120-1840	P
Adapter (Qty 4)	SMA(m)-BNC(f)	1250-1200	P
Adapter	SMA(f)-BNC(m)	1250-2015	P
Coupler	BNC (m-m)	1250-0216	P
20:1 Probes (Qty 2)		54006A	P
BNC Test Connector, 17x2 (Qty 1)**			P
BNC Test Connector, 6x2 (Qty 4)**			P, T

A = Adjustment, P = Performance Tests, T = Troubleshooting

\*\*Instructions for making these test connectors are in chapter 3, "Testing Performance."



---

## Preparing for Use

This chapter gives you instructions for preparing the logic analyzer module for use.

## Power Requirements

All power supplies required for operating the logic analyzer are supplied through the backplane connector in the mainframe.

## Operating Environment

The operating environment is listed in chapter 1. Note the non-condensing humidity limitation. Condensation within the instrument can cause poor operation or malfunction. Provide protection against internal condensation.

The logic analyzer module will operate at all specifications within the temperature and humidity range given in chapter 1. However, reliability is enhanced when operating the module within the following ranges:

Temperature: +20 °C to +35 °C (+68 °F to +95 °F)

Humidity: 20% to 80% non-condensing

## Storage

Store or ship the logic analyzer in environments within the following limits:

- Temperature: -40 °C to +75 °C (-40 °F to +167 °F)
- Humidity: Up to 90% at 65 °C
- Altitude: Up to 15,300 meters (50,000 feet)

Protect the module from temperature extremes which cause condensation on the instrument.

---

## To inspect the module

- 1** Inspect the shipping container for damage.

If the shipping container or cushioning material is damaged, keep them until you have checked the contents of the shipment and checked the instrument mechanically and electrically.

- 2** Check the supplied accessories.

Accessories supplied with the module are listed in chapter 1, "Accessories Supplied."

- 3** Inspect the product for physical damage.

Check the module and the supplied accessories for obvious physical or



mechanical defects. If you find any defects, contact your nearest Agilent Technologies Sales Office. Arrangements for repair or replacement are made, at Agilent Technologies' option, without waiting for a claim settlement.

---

## To prepare the mainframe

---

### CAUTION:

Turn off the mainframe power before removing, replacing, or installing the module.

---

### CAUTION:

Electrostatic discharge can damage electronic components. Use grounded wrist-straps and mats when performing any service to this module.

---

- 1** Remove power from the instrument.
  - a** Exit all logic analysis sessions. In the session manager, select Shutdown.
  - b** At the query, select Power Down.
  - c** When the “OK to power down” message appears, turn the instrument off.
  - d** Disconnect the power cord.
  - e** Disconnect any input or output connections.

- 2** Plan your module configuration.

If you are installing a one-card module, use any available slot in the mainframe.

If you are installing a multi-card module, use adjacent slots in the mainframe.

- 3** Loosen the thumb screws.

Cards or filler panels below the slots intended for installation do not have to be removed.

Starting from the top, loosen the thumb screws on filler panels and cards that need to be moved.

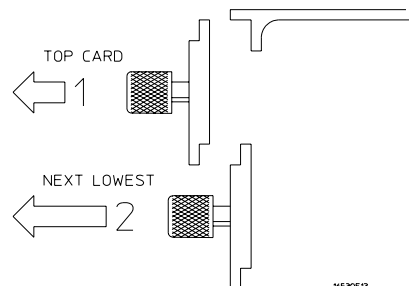

4530E13

- 4 Starting from the top, pull the cards and filler panels that need to be moved halfway out.

---

**CAUTION:**

---

All multi-card modules will be cabled together. Pull these cards out together.

- 5 Remove the cards and filler panels.

Remove the cards or filler panels that are in the slots intended for the module installation. Push all other cards into the card cage, but not completely in. This is to get them out of the way for installing the module.

Some modules for the Logic Analysis System require an operational accuracy calibration if you move them to a different slot. For calibration information, refer to the manuals for the individual modules.

---

## To configure a one-card module

- When shipped separately, the module is configured as a one-card module. The cables should be connected as shown in the figure.
- To configure a multicard module into one-card modules, remove the cables connecting the cards. Then connect the free end of the 2x10 cable to the connector labeled "Master" (J6) on each card (see figure below).

---

**CAUTION:**

---

If you pull on the flexible ribbon part of the 2x10 cable, you might damage the cable assembly. Using your thumb and finger, grasp the ends of the cable connector. Apply pressure to the ends of the cable connector to disengage the metal locking tabs of the connector from the cable socket on the board. Then pull the connector from the cable socket.

---

**NOTE:**

---

Save unused cables for future configurations.

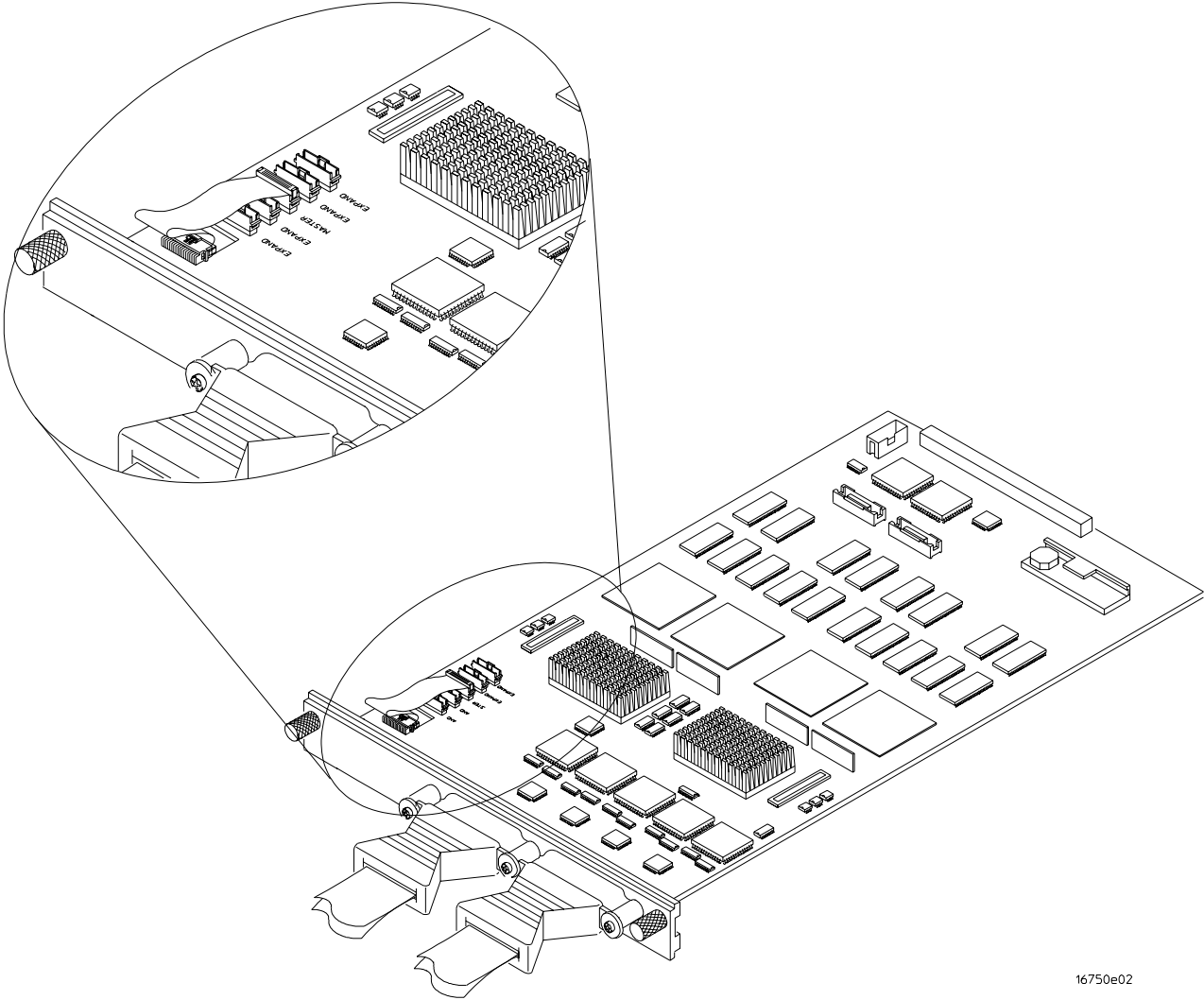

16750e02

---

## To configure a multi-card module

- 1 Plan the configuration. Multicard modules can only be connected as shown in the illustration. Select the card that will be the master card, and set the remaining cards aside.

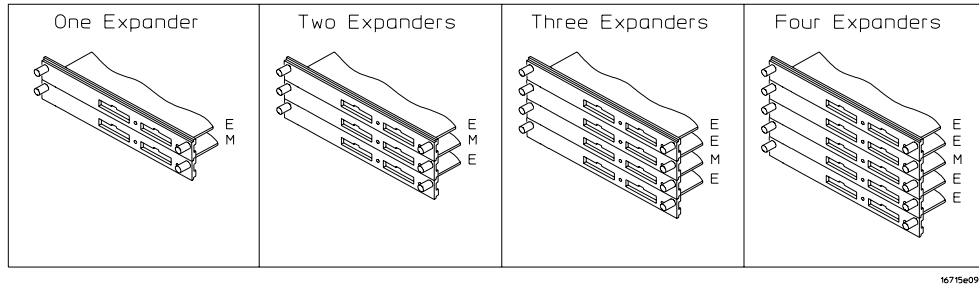

- 2 Obtain two 2x40 cables from the accessory pouch for every expander card being configured.

One Expander: Two 2x40 cables

Two Expanders: Four 2x40 cables

Three Expanders: Six 2x40 cables

Four Expanders: Eight 2x40 cables.

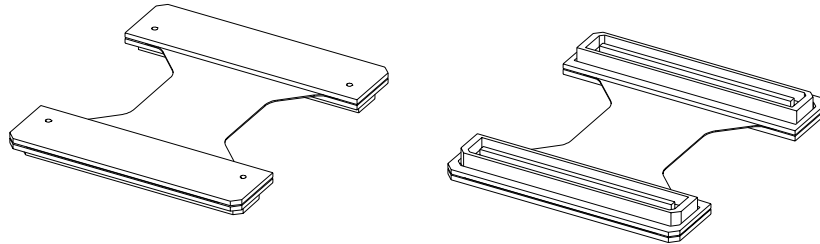

- 3** Connect a 2x40 cable to J9 and to J10 of each card in the multicard configuration.

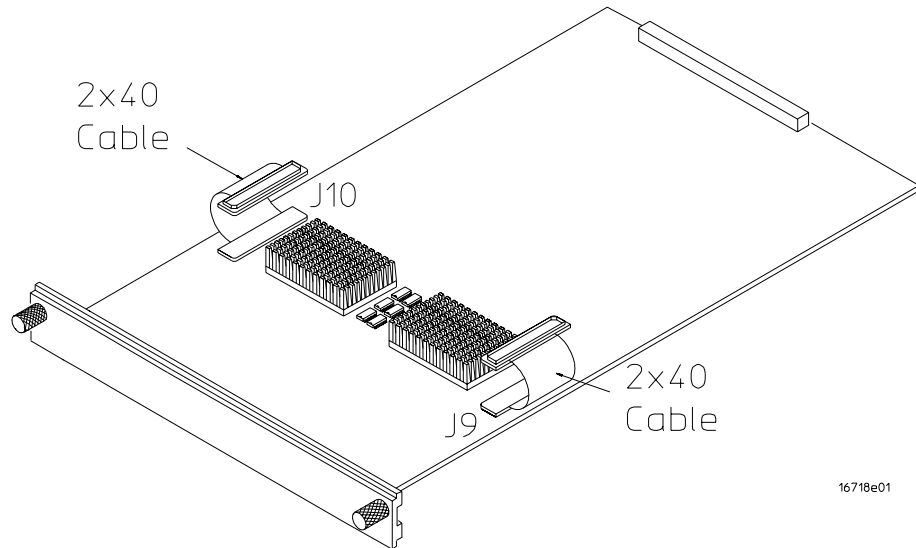

- 4** On the expander cards, disconnect the end of the 2x10 cable that is plugged into the connector labeled "Master."

---

**CAUTION:**

If you pull on the flexible ribbon part of the 2x10 cable, you might damage the cable assembly. Using your thumb and finger, grasp the ends of the cable connector. Apply pressure to the ends of the cable connector to disengage the metal locking tabs of the connector from the cable socket on the board. Then pull the connector from the cable socket.

---

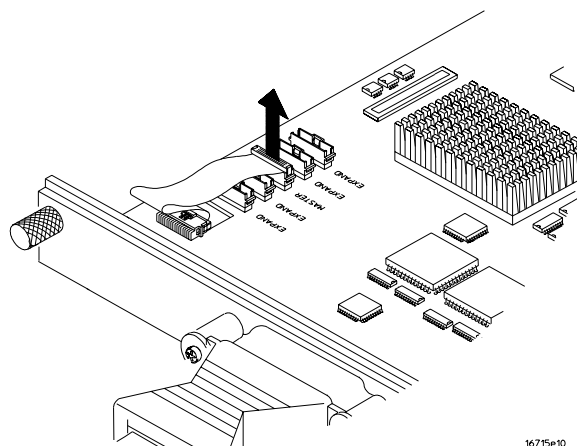

- 5 Begin stacking the cards together according to the drawing under step 1. While stacking, connect the free end of the 2x40 cable on the lower card J9 to J14 of the upper card, on the underside of the card. Connect the free end of the 2x40 cable on the lower card J10 to J15 of the upper card, on the underside of the card

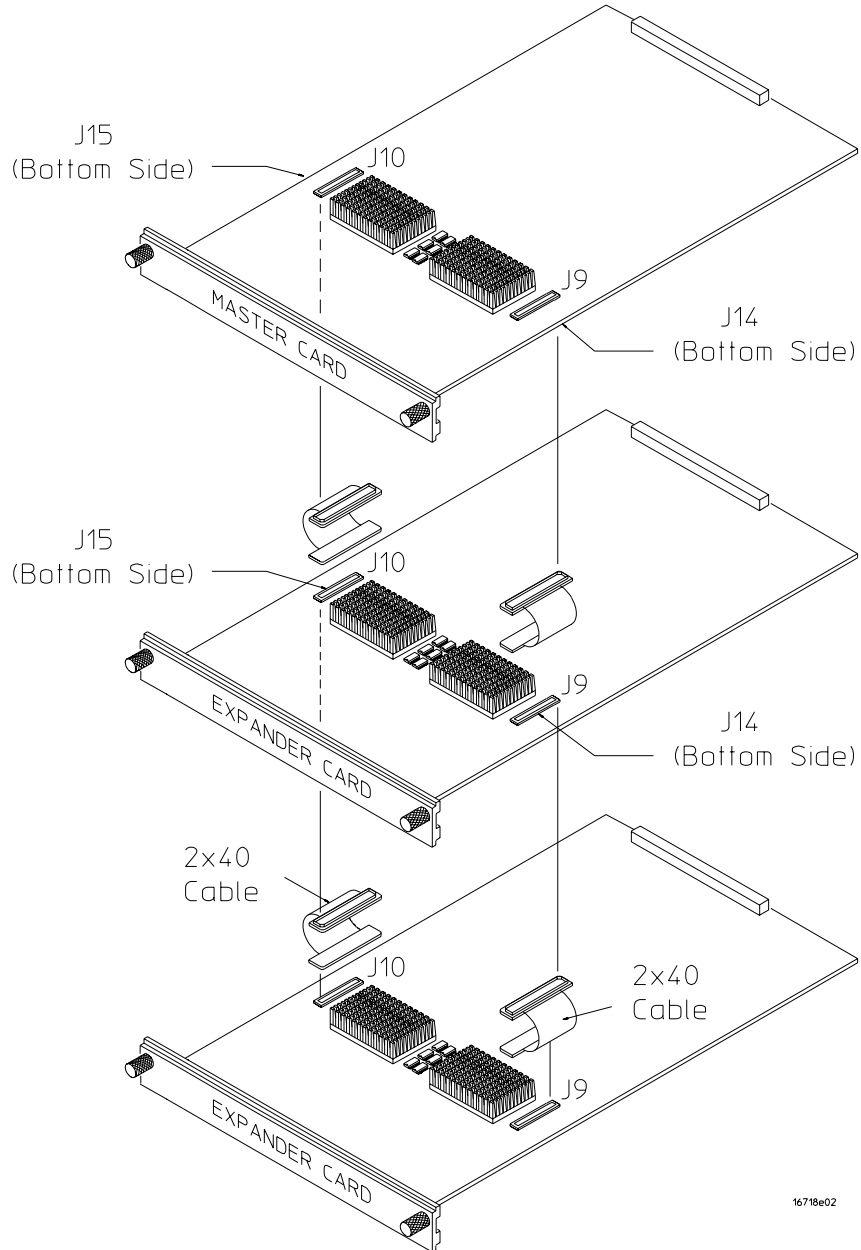

16718e02

- 6 Feed the free end of the 2x10 cables of the lower expander cards through the access holes to the master card. Plug the 2x10 cables into J4 (bottom-most expander in a five-card configuration) and J5 (expander that is next to the master card) on the master card.

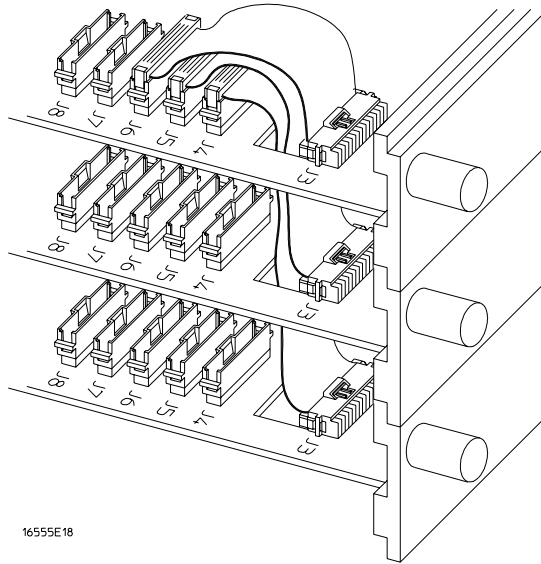

16555E18

- 7 Stack the remaining expander boards on top of the master board. While stacking, connect the free end of the 2x40 cables on the lower card J10 and J9 to the upper card J15 and J14.

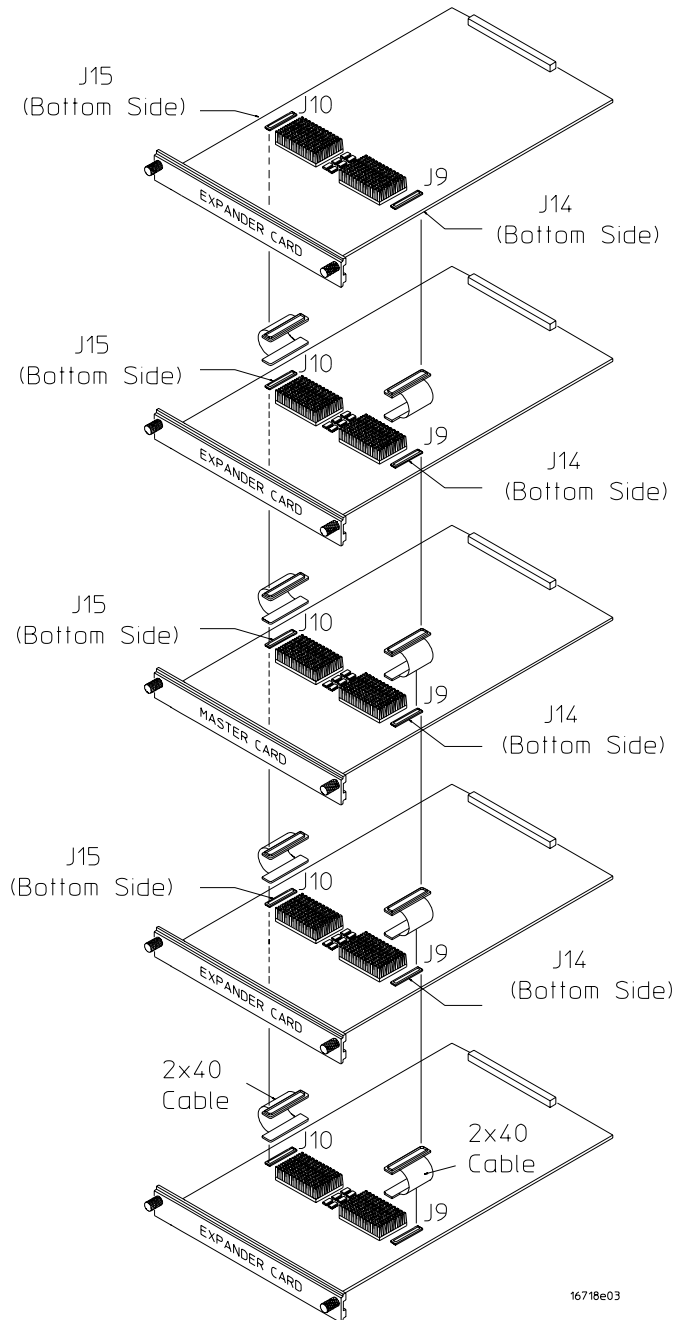



- 8 Feed the free end of the 2x10 cables of the expander cards through the access holes to the master card. Plug the 2x10 cables into J7 (expander that is next to the master card) and J8 (top-most expander in a four- or five-card configuration) on the master card.

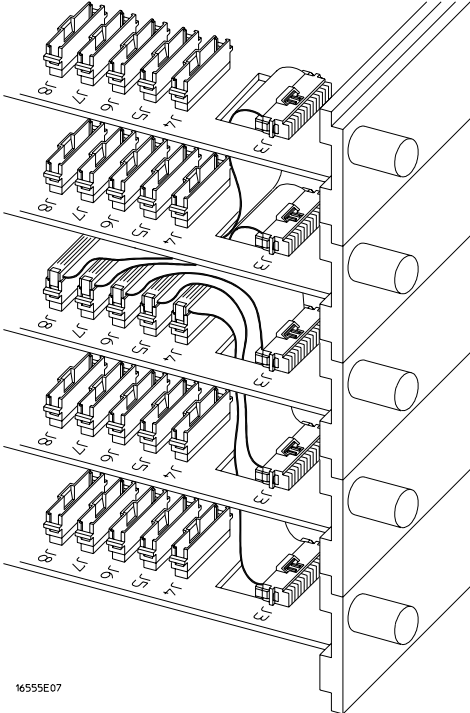

---

## To install the module

- 1** Slide the cards above the slots for the module about halfway out of the mainframe.
- 2** With the probe cables facing away from the instrument, slide the module approximately halfway into the mainframe.

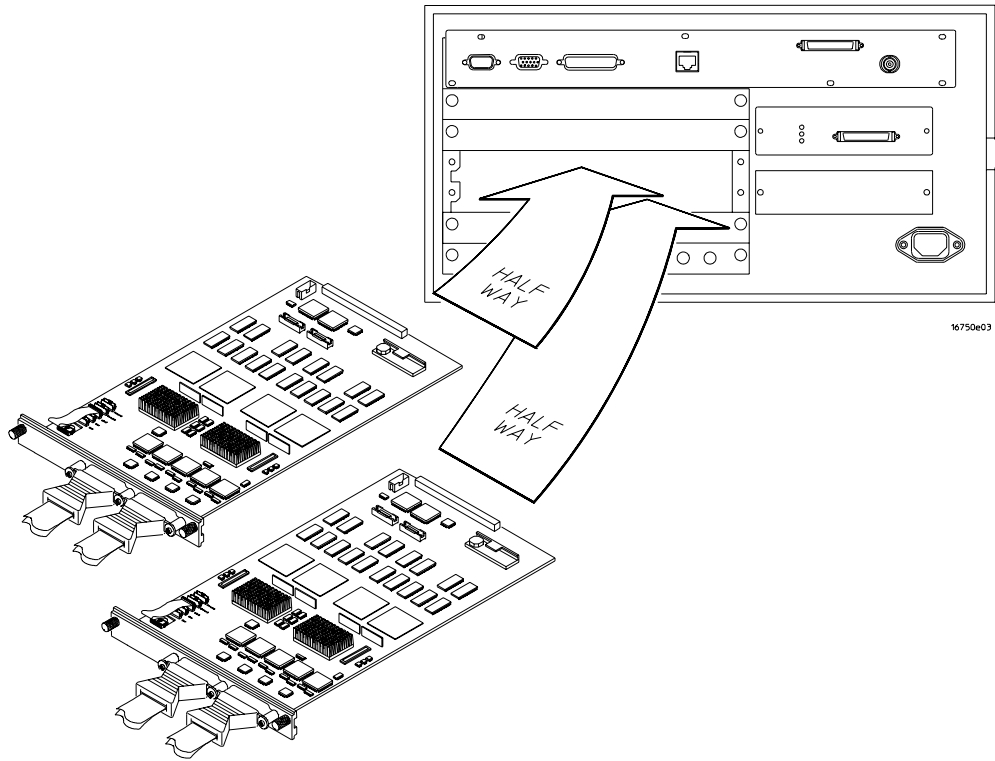

- 3** Slide the complete module into the mainframe, but not completely in.  
Each card in the instrument is firmly seated and tightened one at a time in step 5.
- 4** Position all cards and filler panels so that the endplates overlap.

**5** Seat the cards and tighten the thumbscrews.

Starting with the bottom card, firmly seat the cards into the backplane connector of the mainframe. Keep applying pressure to the center of the card endplate while tightening the thumbscrews finger-tight. Repeat this for all cards and filler panels starting at the bottom and moving to the top.

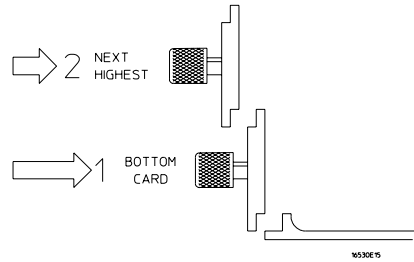

---

**CAUTION:**

Correct air circulation keeps the instrument from overheating. For correct air circulation, filler panels must be installed in all unused card slots. Keep any extra filler panels for future use.

---

---

## To turn on the system

- 1 Connect the power cable to the mainframe.
- 2 Turn on the instrument power switch.

When you turn on the instrument power switch, the instrument performs powerup tests that check mainframe circuitry. After the powerup tests are complete, the screen will look similar to the sample screen below.

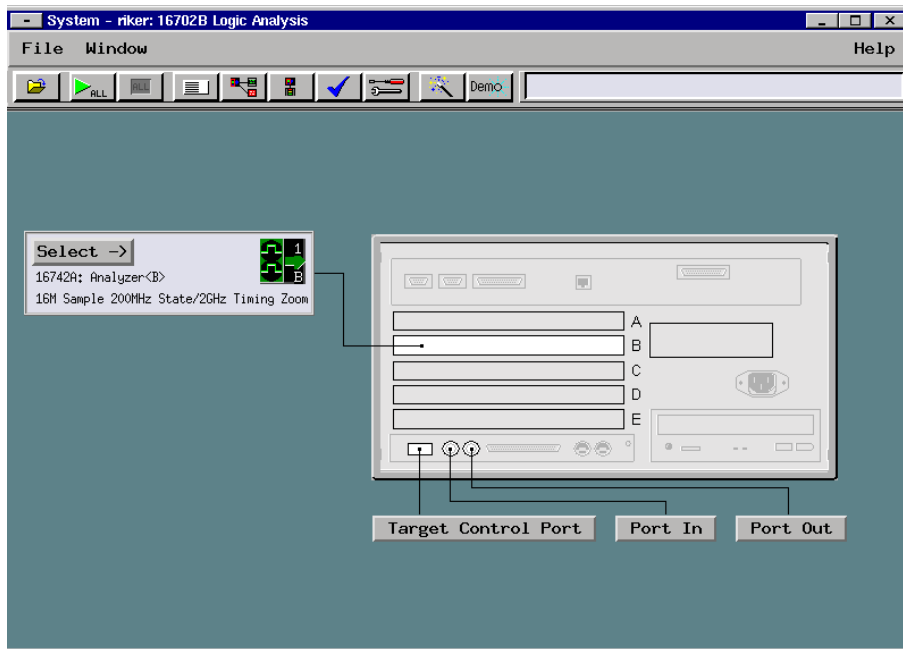

---

## To test the module

The logic analyzer module does not require an operational accuracy calibration or adjustment. After installing the module, you can test and use the module.

- If you require a test to verify the specifications, start at the beginning of chapter 3, "Testing Performance."
- If you require a test to initially accept the operation, perform the self-tests in chapter 3.
- If the module does not operate correctly, go to the beginning of chapter 5, "Troubleshooting."

---

## To clean the module

- With the mainframe turned off and unplugged, use mild detergent and water to clean the rear panel.
- Do not attempt to clean the module circuit board.



---

## Testing Performance

This chapter tells you how to test the performance of the logic analyzer against the specifications listed in chapter 1.

To ensure the logic analyzer is operating as specified, software tests (self-tests) and manual performance tests are done. The logic analyzer is considered performance-verified if all of the software tests and manual performance tests have passed. The procedures in this chapter indicate what constitutes a “Pass” status for each of the tests.

### **Test Strategy**

This chapter shows the module being tested in an Agilent Technologies 16700B-series mainframe. For a complete test, start at the beginning with the software tests and continue through to the end of the chapter. For an individual test, follow the procedure in the test.

**One-card Module.** To perform a complete test on a one-card module, start at the beginning of the chapter and follow each procedure.

**Multi-card Module.** To perform a complete test on a multi-card module, perform the self-tests with the cards connected. Then, remove the multi-card module from the mainframe and configure each card as a one-card module. Install the one-card modules into the mainframe and perform the one-card manual performance verification tests on each card. When the tests are complete, remove the one-card modules, reconfigure them into a multi-card module, reinstall it into the mainframe and perform the final multi-card test. For removal instructions, see Chapter 6, “Replacing Assemblies.” For installation and configuration instructions, see Chapter 2, “Preparing for Use.”

### **Test Interval**

Test the performance of the module against specifications at two-year intervals.

### **Test Record Description**

A performance test record for recording the results of each procedure is located at the end of this chapter. Use the performance test record to gauge the performance of the module over time.

### **Test Equipment**

Each procedure lists the recommended test equipment. You can use equipment that satisfies the specifications given. However, the procedures are based on using the recommended model or part number.

### **Instrument Warm-Up**

Before testing the performance of the module, warm-up the instrument and the test equipment for 30 minutes.



## To Perform the Self-tests

There are two types of self-tests: self-tests that automatically run at power-up, and self-tests that you select on the screen. The self-tests verify the correct operation of the logic analysis system. Self-tests can be performed all at once or one at a time. While testing the performance of the logic analysis system, run the self-tests all at once.

---

### Perform the power-up tests

The logic analysis system automatically performs power-up tests when you apply power to the instrument. Any errors are reported in the boot dialogue. Serious errors will interrupt the boot process.

The power-up tests are designed to complement the instrument on-line Self Tests. Tests that are performed during power-up are not repeated in the Self Tests.

The monitor, keyboard and mouse must be connected to the mainframe to observe the results of the power-up tests.

**1** Disconnect all inputs and exit all logic analysis sessions.

In the Session Manager, select **Shutdown**. In the window, select **Powerdown**.

**2** When the “OK to power down” message appears, turn off the power switch.

**3** After a few seconds, turn the power switch back on. Observe the boot dialogue for the following:

- ensure all of the installed memory is recognized
- any error messages
- interrupt of the boot process with or without error message

A complete transcript of the boot dialogue is in the *Agilent Technologies 16700B-Series Logic Analysis System Service Guide*, Chapter 8, “Theory of Operation”.

**4** During initialization, check for any failures.

If an error or an interrupt occurs, refer to the *Agilent Technologies 16700B-Series Logic Analysis System Service Guide*, Chapter 5, “Troubleshooting”.

## Perform the self-tests

The self-tests verify the correct operation of the logic analysis system and the installed 16740/41/42A module. Self-tests can be performed all at once or one at a time. While testing the performance of the logic analysis system, run the self-tests all at once.

**1** Launch the Self-Tests.

- a** In the System window, click on System Admin.
- b** Under the Admin tab, click on Self-Test. . .
- c** In the query pop-up, select Yes to exit the current session.

The Self-Test closes down the current session because the test algorithms leave the system in an unknown state. Re-launching a session at the end of the tests will ensure the system is properly initialized.

**2** In the Self-Test window select Test All.

When the tests are finished, the Status will change to TEST passed or TEST failed. You can find detailed information about the test results in the Status Message field of the Self-Test window.

The System CPU Board test returns Untested because the CPU tests require user action. To test the CPU Board, select CPU Board, then select each test individually.

**3** Select Quit to exit the Test menu.

**4** In the Session Manager, select Start Session to re-launch a logic analysis session.

---

## To Set Up the Test Connectors

The test connectors connect the logic analysis system to the test equipment.

### Materials Required

Description	Recommended HP/ Agilent Part	Qty
BNC (f) Connector	1250-1032	4
100 $\Omega$ 1% resistor	0698-7212	6
Berg Strip, 17-by-2		1
Berg Strip, 6-by-2		3
20:1 Probe	54006A	2
Jumper wire		

- 1** Build three test connectors using BNC connectors and 6-by-2 sections of Berg strip.
  - a** Solder a jumper wire to all pins on one side of the Berg strip.
  - b** Solder a jumper wire to all pins on the other side of the Berg strip.
  - c** Solder two resistors to the Berg strip, one at each end between the end pins.
  - d** Solder the center of the BNC connector to the center pin of one row on the Berg strip.

Chapter 3: Testing Performance  
To Set Up the Test Connectors

- e Solder the ground tab of the BNC connector to the center pin of the other row on the Berg strip.
- f On two of the test connectors, solder a 20:1 probe. The probe ground goes to the same row of pins on the test connector as the BNC ground tab.

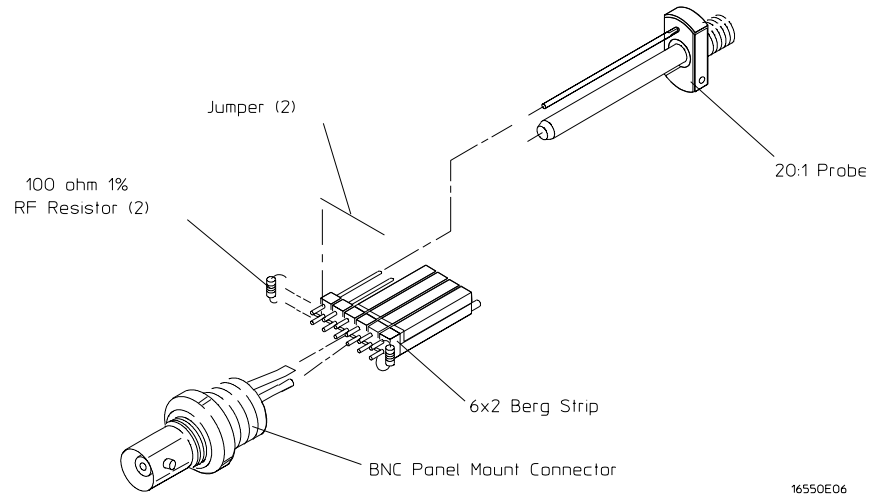

- 2** Build one test connector using a BNC connector and a 17-by-2 section of Berg strip.
- a** Solder a jumper wire to all pins on one side of the Berg strip.
  - b** Solder a jumper wire to all pins on the other side of the Berg strip.
  - c** Solder the center of the BNC connector to the center pin of one row on the Berg strip.
  - d** Solder the ground tab of the BNC connector to the center pin of the other row on the Berg strip.

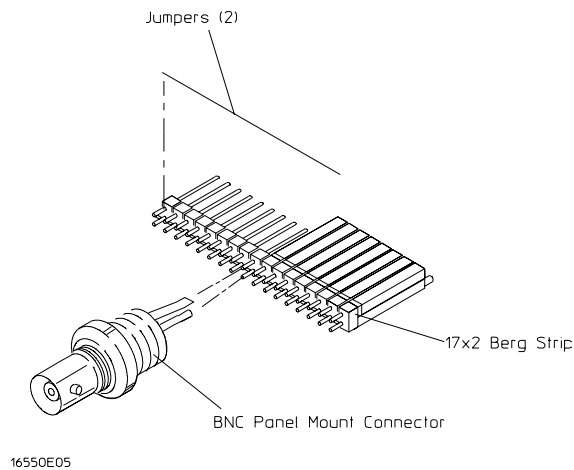

---

## To Set up the Test Equipment and the Analyzer

Before testing the specifications of the 16740/41/42A logic analyzer, the test equipment and the logic analysis system must be set up and configured.

These instructions include detailed steps for initially setting up the required test equipment and the logic analysis system. Before performing any or all of the following tests in this chapter, the following steps must be followed.

---

**NOTE:**

---

Multi-card modules must be separated into single-card modules.

### Equipment Required

Equipment	Critical Specifications	Recommended HP/Agilent Model/Part
Pulse Generator	200 Mhz, 2.5 ns pulse width, < 600 ps rise time	8133A option 003
Digitizing Oscilloscope	≥ 6 GHz bandwidth, < 58 ps rise time	54750A w/ 54751A
Digital Multimeter	0.1 mV resolution, 0.005% accuracy	3458A
Function Generator	DC offset voltage ± 1.5 V	3325B Option 002

---

### Set up the equipment

- 1 Turn on the required test equipment listed in the table above. Let them warm up for 30 minutes before beginning any test.
  - 2 Turn on the logic analysis system.
    - a Connect the keyboard, mouse, and monitor to the rear panel of the logic analysis system mainframe (16700B only).
    - b Plug in the power cord to the power connector on the rear panel of the mainframe.
    - c Turn on the main power switch on the mainframe front panel.
  - 3 Set up the logic analysis system.
    - a Open the Session Manager window and select “Start Session”.
    - b In the Logic Analysis System window, select the module icon, then select Setup. A Setup window opens.
    - c In the Setup window, select Window, then select Slot n: Analyzer<n> (where “n” is the slot the module under test is installed), then select Listing. A Listing window opens.
-

- d** In the Analyzer<n> Setup window, select the Sampling tab.
- 4** Set up the pulse generator according to the following table.

Timebase	Channel 2	Trigger	Channel 1
Mode: Int Period: 5.000 ns	Mode: Pulse Divide: Pulse ÷ 2 Width: 2.500 ns High: -0.90 V Low: -1.70 V COMP: Disabled (LED Off)	Divide: Divide ÷ 2 Ampl: 0.50 V Offs: 0.00 V	Mode: Square Delay: 0.000 ns High: -0.90 V Low: -1.70 V COMP: Disabled (LED Off)

- 5** Set up the oscilloscope.
- a** Select Setup, then select Default Setup.
- b** Configure the oscilloscope according to the following table.

**Oscilloscope Setup**

Acquisition	Display	Trigger	[Shift] Δ Time
Averaging: On # of averages: 16	Graticule graphs: 2	Level: 0.0 mV	Stop src: channel 2 [Enter]

Channel 1	Channel 2	Define meas
External Scale Attenuation: 20.00:1 Scale: 200 mV/div Offset: - 1.300 V	External Scale Attenuation: 20.00:1 Scale: 200 mV/div Offset: - 1.300 V	Thresholds: user-defined Units: Volts Upper: - 980 mV Middle: -1.30 V Lower: -1.62 V

Allow the logic analysis system to warm up for 30 minutes before beginning any of the following tests.

## To Test the Threshold Accuracy

Testing the threshold accuracy verifies the performance of the following specification:

- Clock and data channel threshold accuracy

These instructions include detailed steps for testing the threshold settings of Pod 1. After testing Pod 1, connect and test the rest of the pods one at a time. To test the next pod, follow the detailed steps for Pod 1, substituting the next pod for Pod 1 in the instructions.

### Equipment Required

Equipment	Critical Specifications	Recommended HP/Agilent Model/Part
Digital Multimeter	0.1 mV resolution, 0.005% accuracy	3458A
Function Generator	DC offset voltage $\pm 1.5$ V	3325B Option 002
BNC-Banana Cable		11001-60001
BNC Tee		1250-0781
BNC Cable		8120-1840
BNC Test Connector, 17x2		

---

### Set up the equipment

- 1 If you have not already done so, perform the procedure described in “To Set up the Test Equipment and the Analyzer” on page 38.
- 2 Set up the function generator.
  - a Set up the function generator to provide a DC offset voltage at the Main Signal output.
  - b Disable any AC voltage to the function generator output, and enable the high voltage output.
  - c Monitor the function generator DC output voltage with the multimeter.



---

## Set up the logic analyzer

- 1 In the Analyzer Setup window, select the Format tab.
- 2 Under the Format tab, select Pod Assignment. Unassign the pods that are assigned to Analyzer 2. To unassign the pods, use the mouse to drag the pods to the Unassigned Pods column.

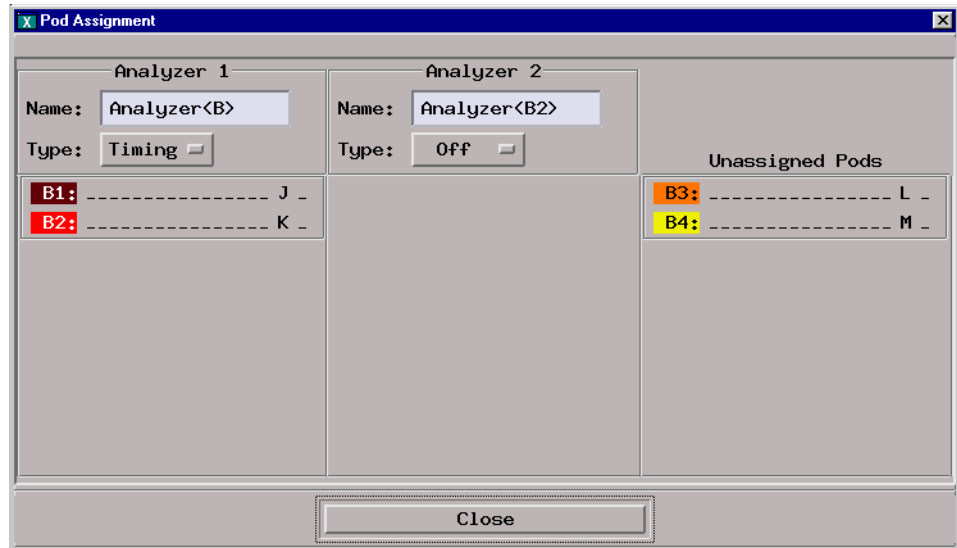

Select Close to close the Pod Assignment Window.

- 3 Under the Format tab, select the Threshold field under Pod 1. Click on the checkbox next to Apply Threshold Setting to all pods to deselect.

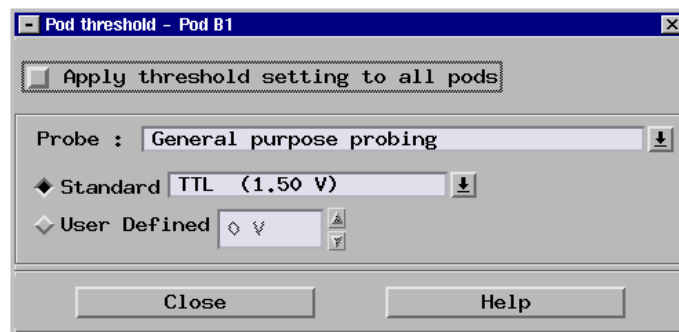

### Connect the logic analyzer

- 1** Using the 17-by-2 test connector, BNC cable, and probe tip assembly, connect the data and clock channels of Pod 1 to one side of the BNC Tee.
- 2** Using a BNC-banana cable, connect the voltmeter to the other side of the BNC Tee.
- 3** Connect the BNC Tee to the Main Signal output of the function generator.

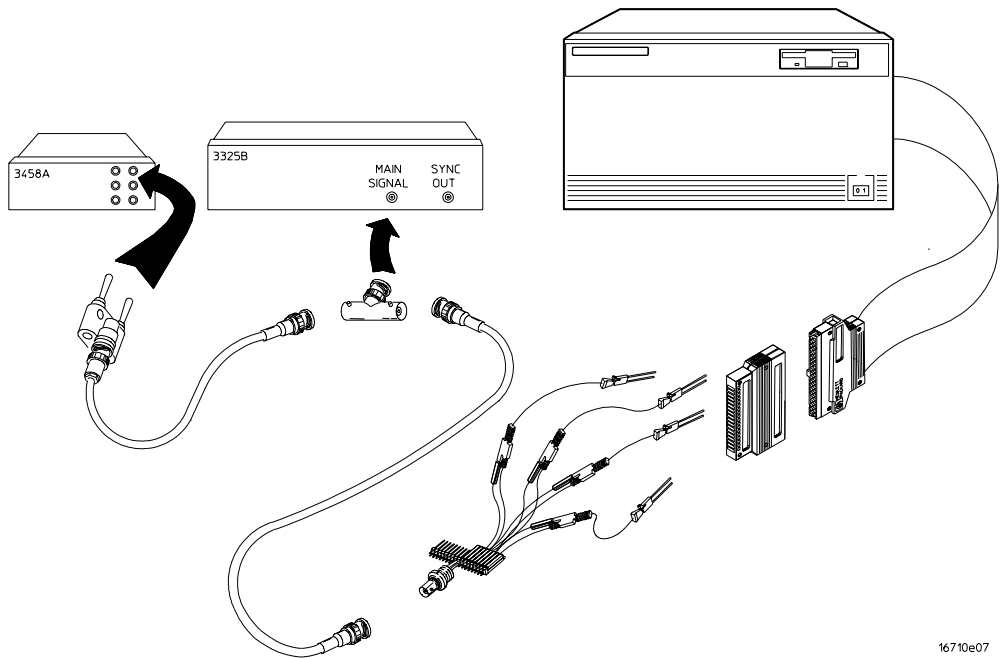

16710e07

## Test the ECL threshold

- 1 In the Pod Threshold window, select the Standard threshold voltage field. At the pop-up menu select ECL (-1.30 V).

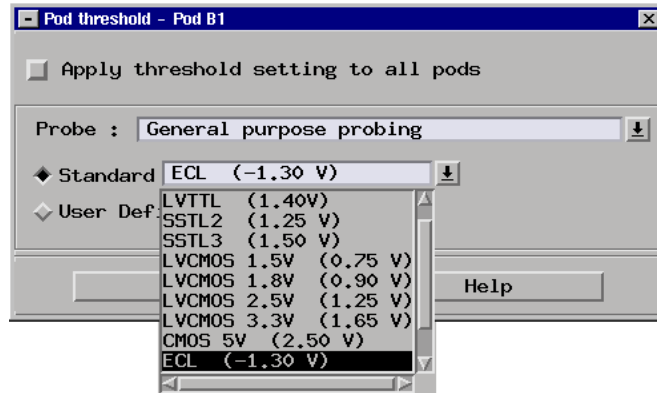

- 2 On the function generator front panel, enter -1.214 V  $\pm$ 1 mV DC offset. Use the multimeter to verify the voltage.

The activity indicators for Pod 1 should show all data channels and the J-clock channel at a logic high.

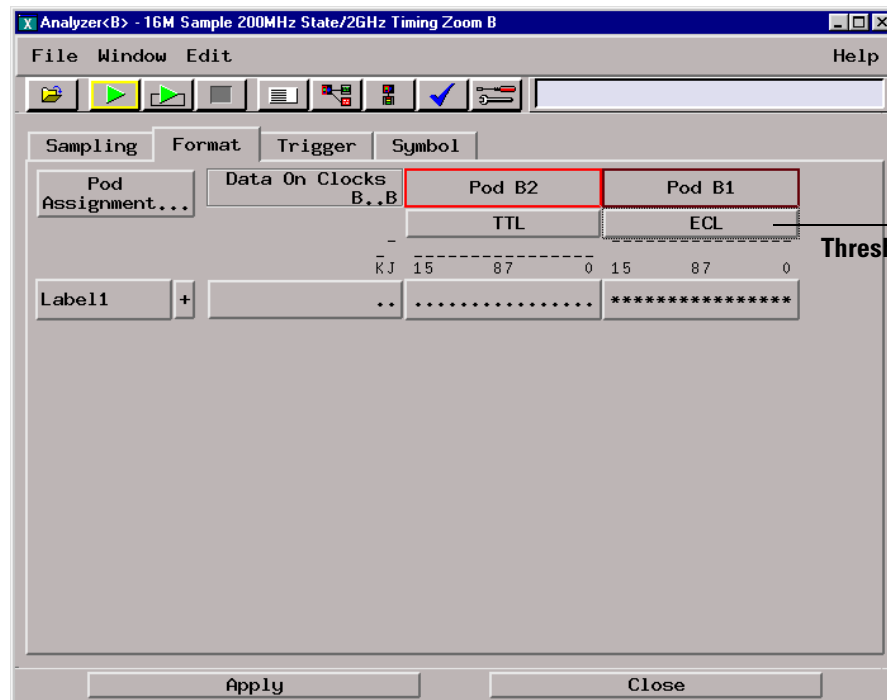

- Using the Modify down arrow on the function generator, decrease offset voltage in 1-mV increments until all activity indicators for the pod under test show the channels are at a logic low. Record the function generator voltage in the performance test record.

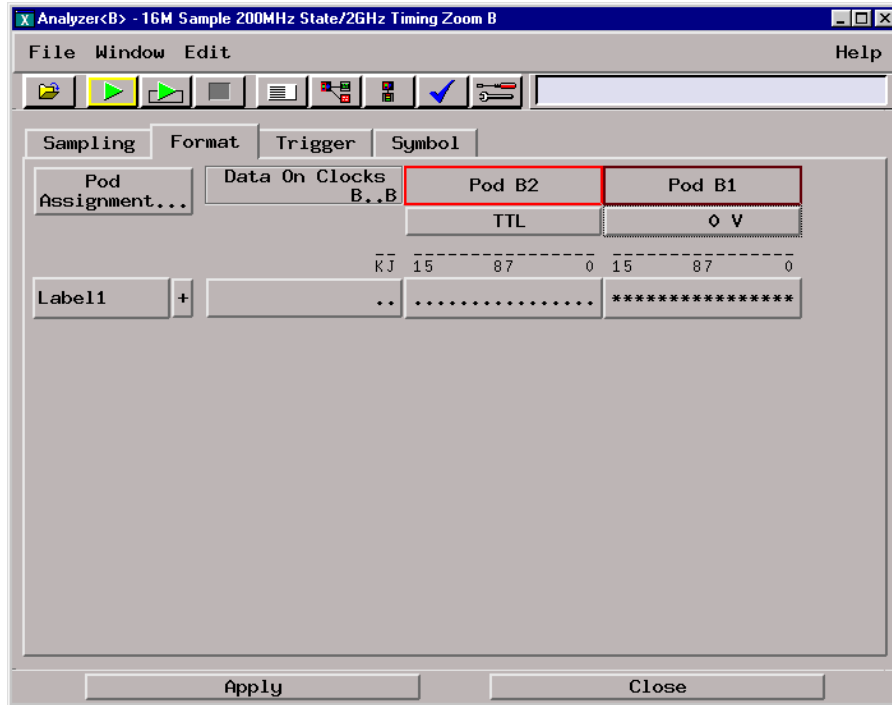

- Using the Modify up arrow on the function generator, increase offset voltage in 1-mV increments until all activity indicators for the pod under test show the channels are at a logic high. Record the function generator voltage in the performance test record.



---

## Test the 0 V User threshold

- 1 In the Pod Threshold window, select User Defined. In the numeric field, enter 0 V.

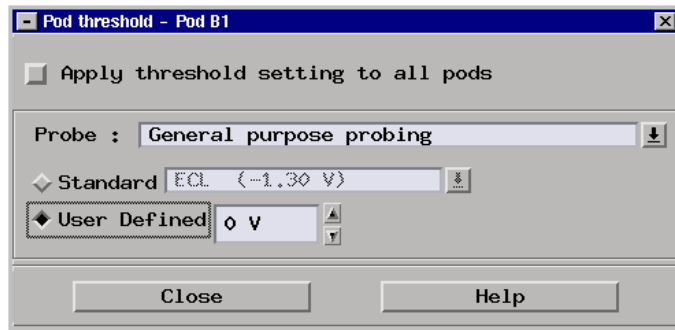

- 2 On the function generator front panel, enter +0.067 V  $\pm$ 1 mV DC offset. Use the multimeter to verify the voltage.

The activity indicators for the pod under test should show all data channels and the J-clock channel at a logic high.

- 3 Using the Modify down arrow on the function generator, decrease offset voltage in 1-mV increments until all activity indicators for the pod under test show the channels at a logic low. Record the function generator voltage in the performance test record.

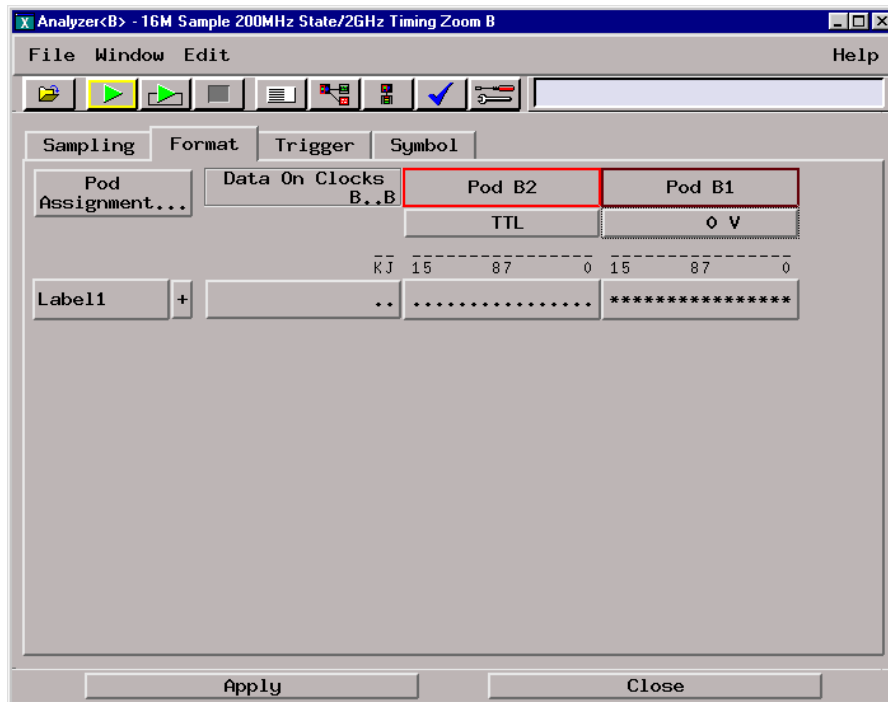

- Using the Modify up arrow on the function generator, increase offset voltage in 1-mV increments until all activity indicators for the pod under test show the channels at a logic high. Record the function generator voltage in the performance test record.

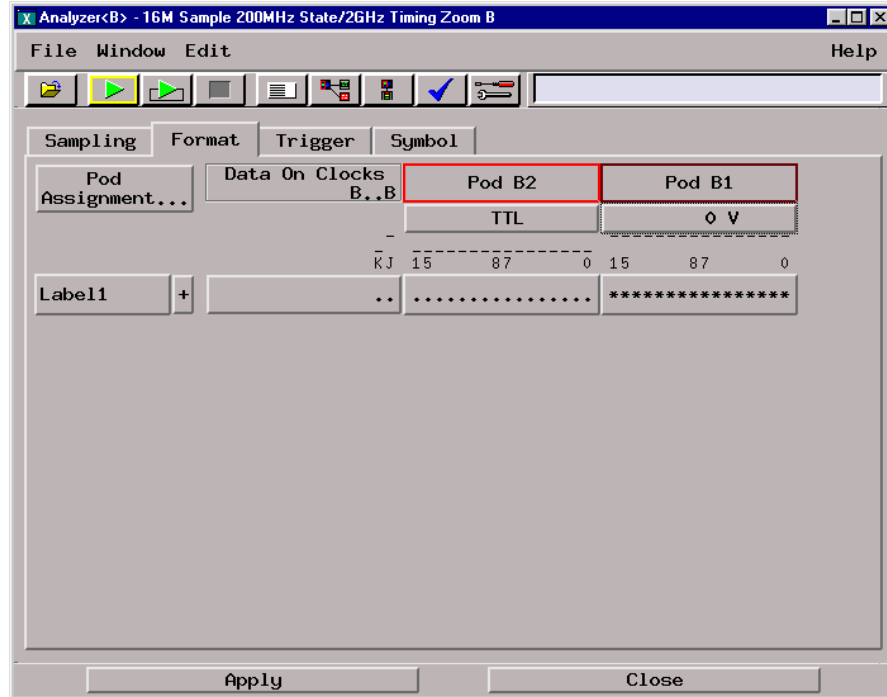

---

## Test the next pod

Using the 17-by-2 test connector and probe tip assembly, connect the data and clock channels of the next pod to the output of the function generator as shown in “Connect the logic analyzer” on page 42. If you have just finished testing Pod 1, connect the data and clock channels of Pod 2. Repeat until all pods have been tested.

Note that the pod under test must be assigned to the analyzer. For Pod 3, use the Pod Assignment menu under the Format tab, unassign Pods 1 and 2 and assign Pods 3 and 4 to Analyzer 1.

When you have finished testing the last pod, you have completed the threshold accuracy test.

## To Test the Single-clock, Single-edge, State Acquisition

Testing the single-clock, single-edge, state acquisition verifies the performance of the following specifications:

- Minimum master to master clock time
- Maximum state acquisition speed
- Setup/Hold time

This test checks a combination of data channels using a single-edge clock at two selected setup/hold times.

### Equipment Required

Equipment	Critical Specifications	Recommended HP/ Agilent Model/Part
Pulse Generator	200 Mhz, 2.5 ns pulse width, < 600 ps rise time	8133A option 003
Digitizing Oscilloscope	≥ 6 GHz bandwidth, < 58 ps rise time	54750A w/ 54751A
Adapter	SMA(m)-BNC(f)	1250-1200
SMA Coax Cable (Qty 3)		8120-4948
Coupler (Qty 3)	BNC (m-m)	1250-0216
BNC Test Connector, 6x2 (Qty 3)		

---

---

### Set up the equipment

If you have not already done so, do the procedure “To Set up the Test Equipment and the Analyzer” on page 38. Ensure that the pulse generator and oscilloscope are set up according to the tables in that section.

---

### Set up the logic analyzer

- 1 Set up the Sampling tab.
  - a In the Analyzer setup window, select the Sampling tab.
  - b Select State Mode.



- 2** Assign all pods to Analyzer 1.
  - a** In the Analyzer setup window, select the Format tab.
  - b** Under the Format tab, select Pod Assignment.
  - c** In the Pod Assignment window, use the mouse to drag the pods to the Analyzer 1 column.

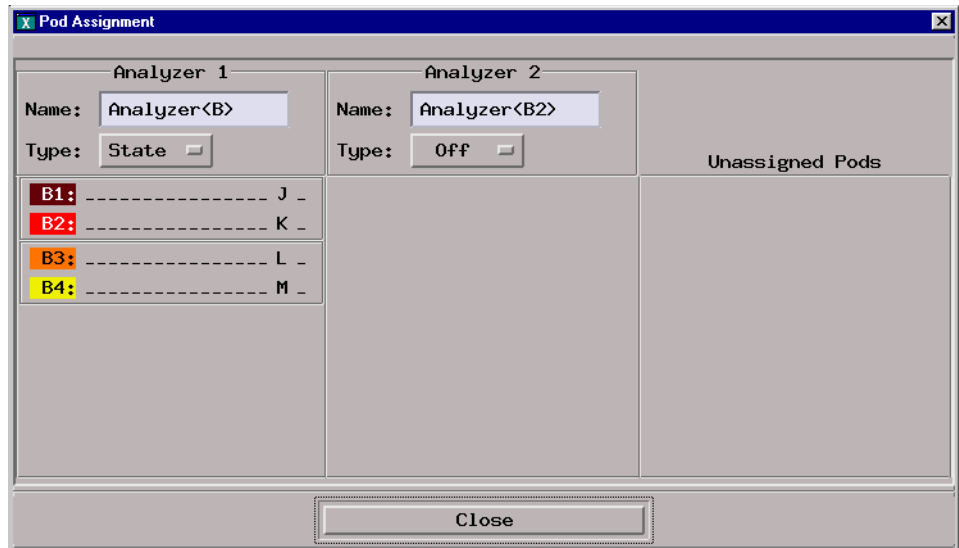

- d** Select Close to close the Pod Assignment window.

**3** Set up the Format tab.

- a** Under one of the pod fields, select TTL.
- b** In the Pod Threshold window, ensure the Apply threshold setting to all pods checkbox is checked.
- c** In the Pod Threshold window, select the Standard threshold voltage field. At the pop-up menu, select ECL (-1.30 V).

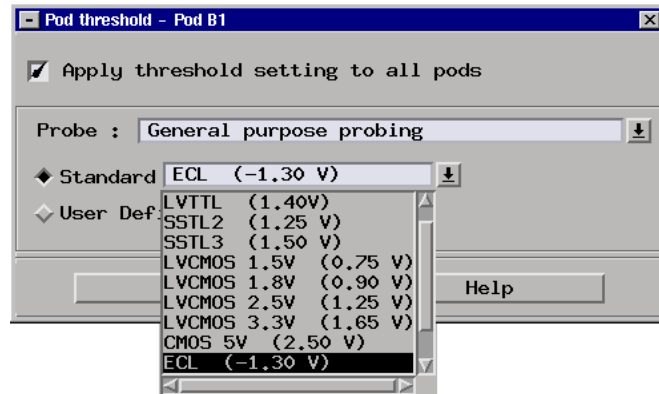

- d** Select Close to close the Pod Threshold window.

- 4 Set up the Trigger tab.
  - a In the Analyzer setup window, select the Trigger tab. Under the Trigger tab, select the Settings tab.
  - b Select the Acquisition Depth field, then select “8K”.
  - c Select the Trigger Position field, then select Start.

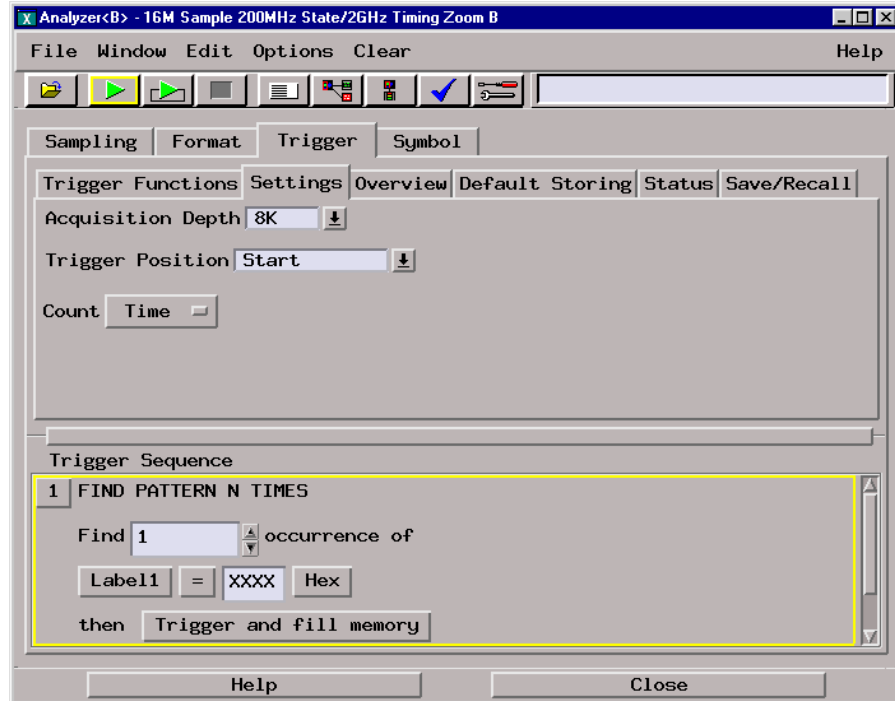

- 5 Set up the Listing window.
  - a In the Listing window, select the Markers tab.
  - b Select the G1: field and the Markers Setup window appears.
  - c Select the Time field associated with G1, and select Pattern. Select the Time field associated with G2, and select Pattern.

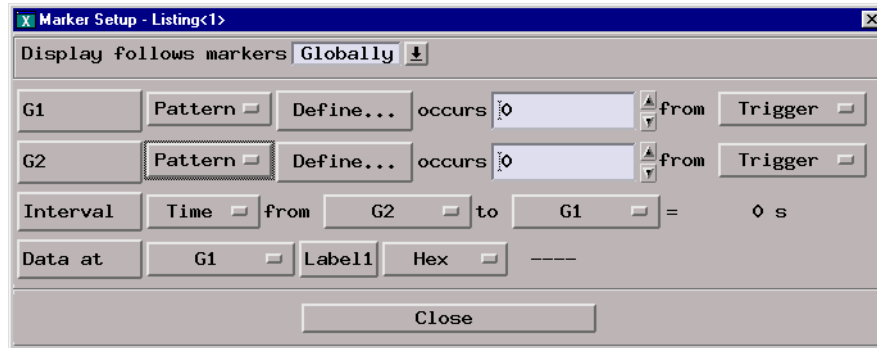

Note: Leave the Marker Setup window open. You will be entering numeric values in the “occurs” field after acquiring the test data.

### Connect the logic analyzer

- 1 Using the 6-by-2 test connectors, connect the logic analyzer clock and data channels listed in the following tables to the pulse generator.
- 2 Using SMA cables, connect channel 1, channel 2, and trigger from the oscilloscope to the pulse generator according to the following illustration.

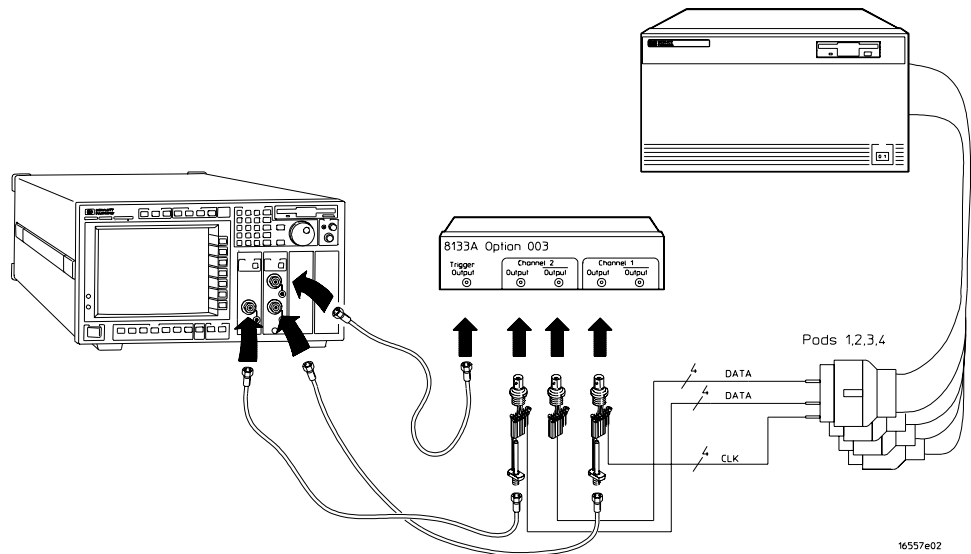

### Connect the 16740/41/42A to the Pulse Generator

8133A Ch2 Output	8133A Ch2 Output	8133A Ch1 Output
Pod 1 channel 3	Pod 1 channel 11	J-clock
Pod 2 channel 3	Pod 2 channel 11	
Pod 3 channel 3	Pod 3 channel 11	
Pod 4 channel 3	Pod 4 channel 11	

- 3** Activate the data channels that are connected according to the previous table.
  - a** In the Analyzer setup window, select the Format tab.
  - b** Under the Format tab, select the field showing the channel assignments for one of the pods being tested, then select Individual. Using the mouse, select the data channels to be tested (channels 11 and 3 of each pod). An asterisk means that a channel is turned on. Follow this step for the remaining pods to be tested.

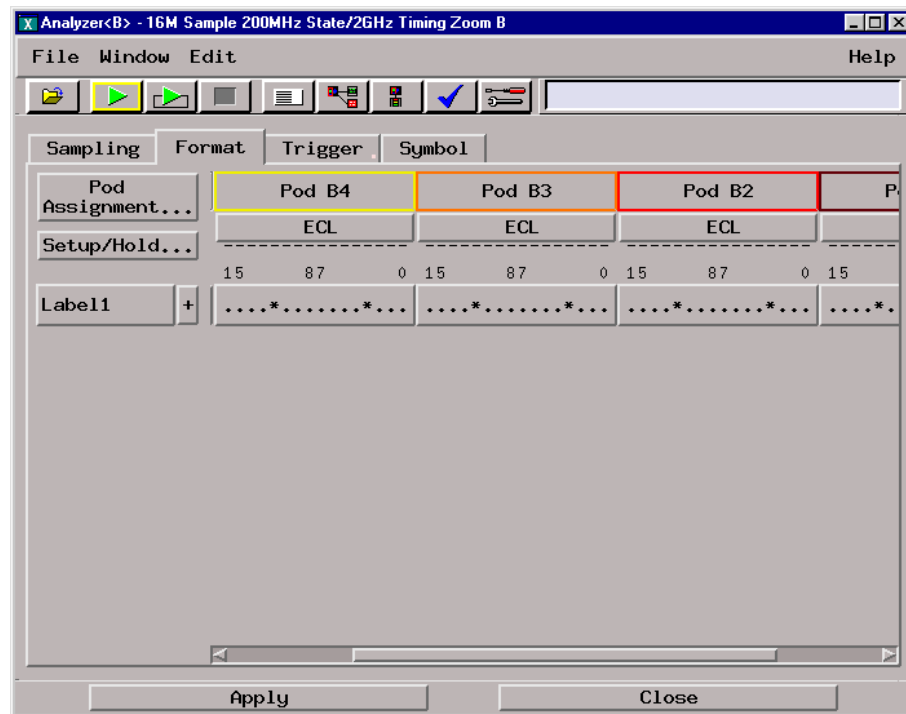

- 4 Configure the trigger pattern.
  - a Select the Trigger tab. Under the Trigger tab, select the Trigger Functions tab.
  - b In the General State field, select Store nothing until pattern occurs. Then select Replace.
  - c Under Trigger Sequence, locate the Label 1 = trigger pattern field. Enter “AA” in the trigger pattern field. The trigger function should now read Store nothing until Label 1 = AA Hex occurs then Trigger and fill memory.

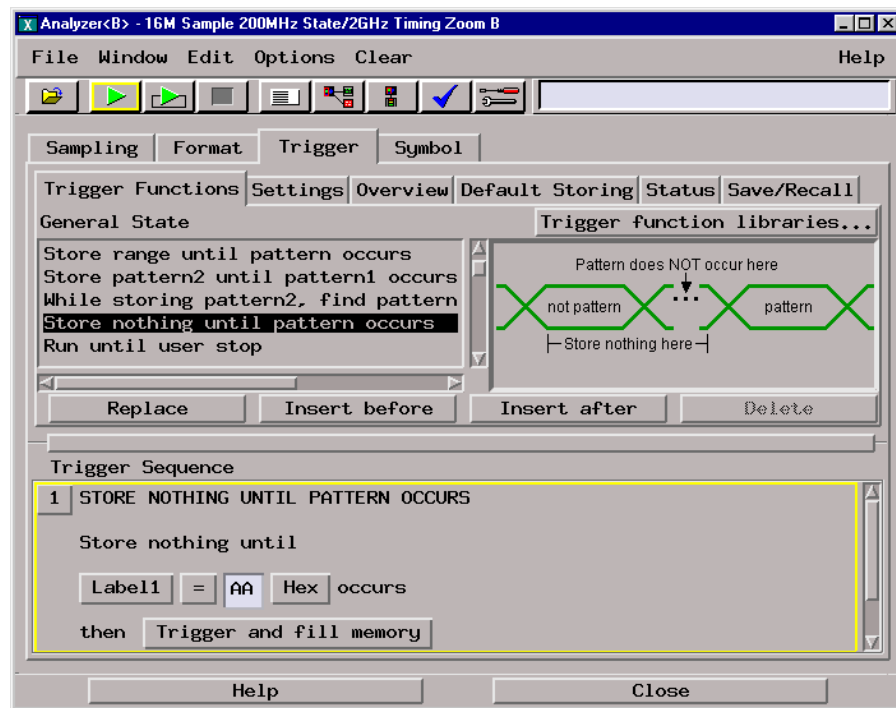

## Verify the test signal

- 1** Check the clock period. Using the oscilloscope, verify that the master-to-master clock time is 5.000 ns, +0 ps or -100 ps.
  - a** Turn on the pulse generator channel 1, channel 2, and trigger outputs.
  - b** In the oscilloscope Timebase menu, select Position. Using the oscilloscope knob, position the clock waveform so that a rising edge appears at the left of the display.
  - c** On the oscilloscope, select [Shift] Period: channel 2, then select [Enter] to display the clock period (Period(2)). If the period is more than 5.000 ns, go to step d. If the period is less than or equal to 5.000 ns but greater than 4.900 ns, go to step 2.
  - d** In the oscilloscope Timebase menu, increase Position 5.000 ns. If the period is more than 5.000 ns, decrease the pulse generator Period in 10 ps increments until one of the two periods measured is less than or equal to 5.000 ns but greater than 4.900 ns.

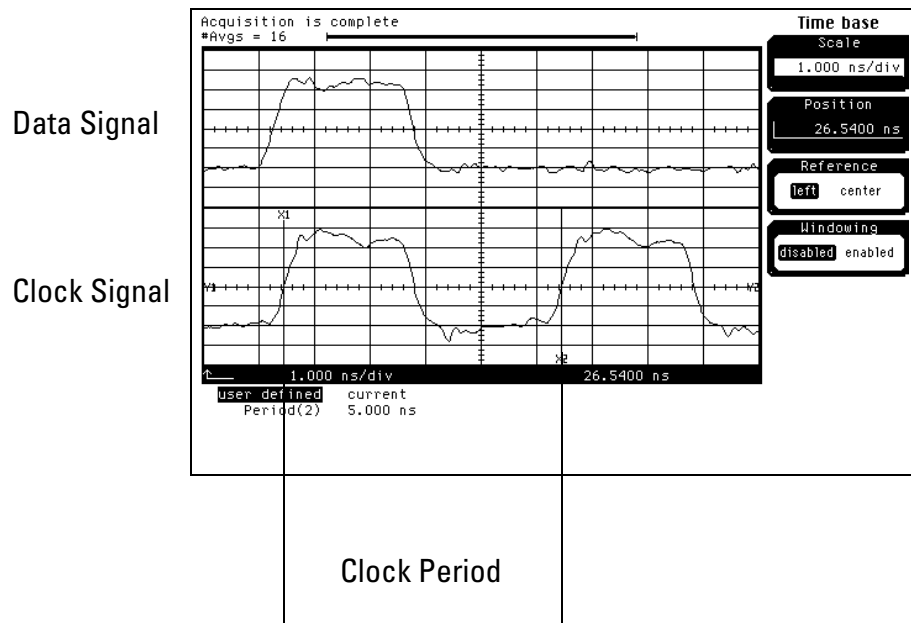



- 2 Check the data pulse width. Using the oscilloscope, verify that the data pulse width is 2.500 ns, +0 ps or -50 ps.
  - a In the oscilloscope Timebase menu, select Position. Using the oscilloscope knob, position the data waveform so that the waveform is centered on the screen.
  - b On the oscilloscope, select [Shift] + width: channel 1, then select [Enter] to display the data signal pulse width (+ width(1)).
  - c If the pulse width is outside the limits, adjust the pulse generator channel 2 width until the pulse width is within limits.

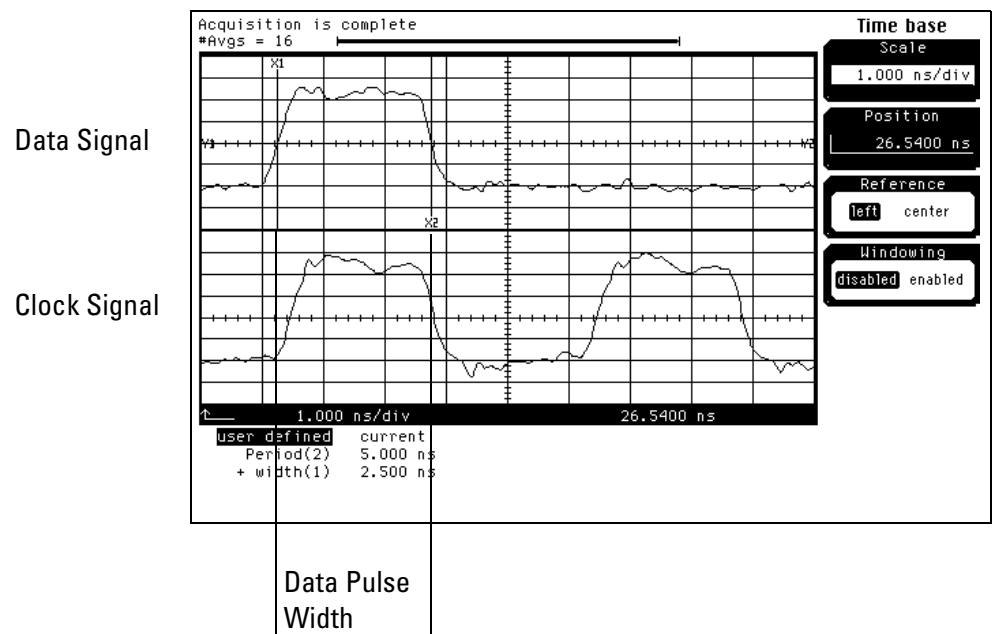

---

## Check the setup/hold combination

- 1 Select the logic analyzer setup/hold time.
  - a In the Analyzer setup window, select the Format tab.
  - b Under the Format tab, select Setup/Hold.
  - c In the Setup and Hold window, ensure All bits is selected.
  - d Enter the setup time of the setup/hold combination to be tested in the Setup: field.

### Setup/Hold Combinations

4.5/-2.0 ns  
-2.0/4.5 ns

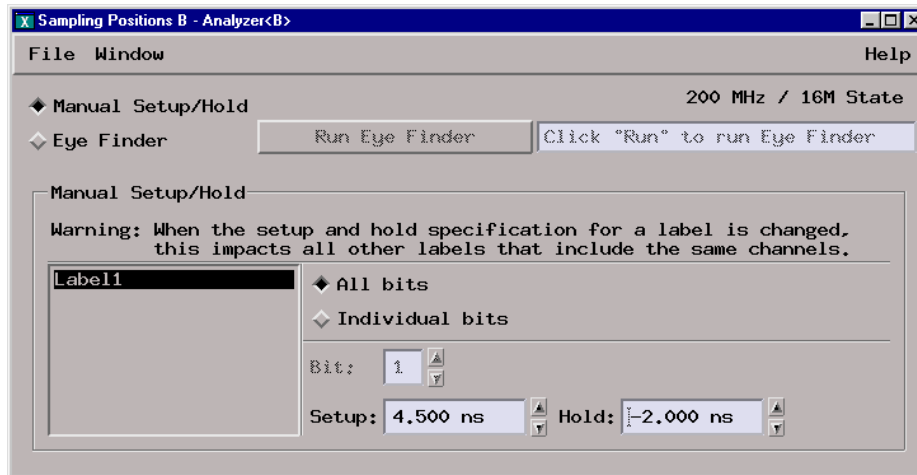

- e Select the close (X) button in the upper-right corner to close the Setup/ Hold window.
- 2 Disable the pulse generator channel 1 COMP (LED off).

- 3 Using the Delay mode of the pulse generator channel 1, position the pulses according to the setup/hold combination selected, +0.0 ps or -50 ps.
  - a On the Oscilloscope, select [Define meas] Define  $\Delta$ Time - Stop edge: rising.
  - b In the oscilloscope timebase menu, select Position. Using the oscilloscope knob, position both a clock and a data waveform on the display, with the rising edge of the clock waveform centered on the display.
  - c On the oscilloscope, select [Shift]  $\Delta$  Time, then select [Enter] to display the setup time ( $\Delta$ Time(1)-(2)).
  - d Adjust the pulse generator channel 1 Delay until the pulses are aligned according the setup time of the setup/hold combination selected, +0.0 ps or -50 ps.

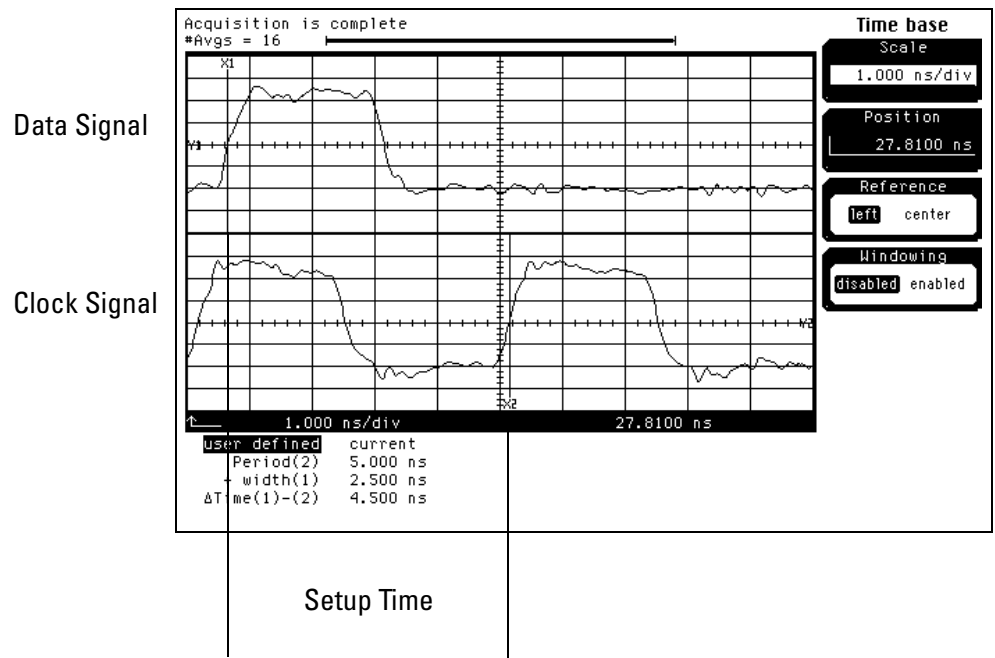

Disregard the Period(2) value. The settings provided in this procedure may measure the period from falling edge to falling edge, which is not a valid measurement.

- 4 Select the clock to be tested.
  - a In the Analyzer setup window, select the Sampling tab.
  - b Under the Sampling tab, select the clock edge field under the clock to be tested. Then select Rising Edge. Turn off all other clocks. The first time through this test, select the first clock and edge.

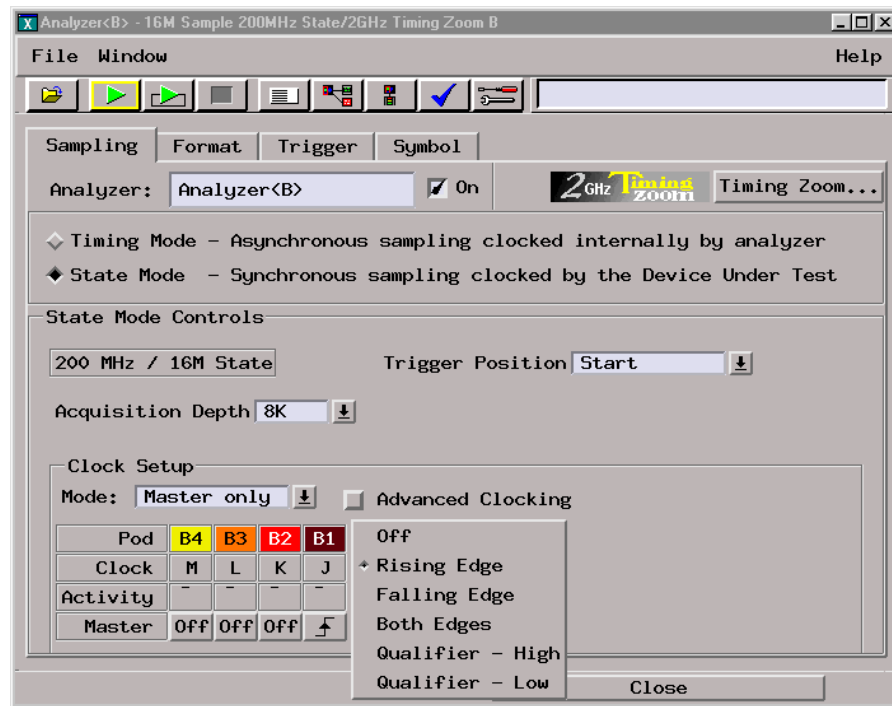

### Clocks

J↑	K↑	L↑	M↑
----	----	----	----

- c Connect the clock input channel to be tested to the pulse generator channel 1 OUTPUT. Disconnect all other clock input channels.

5 Verify the test data.

- a In the Listing window, select Run. The display should show an alternating pattern of “AA” and “55”.

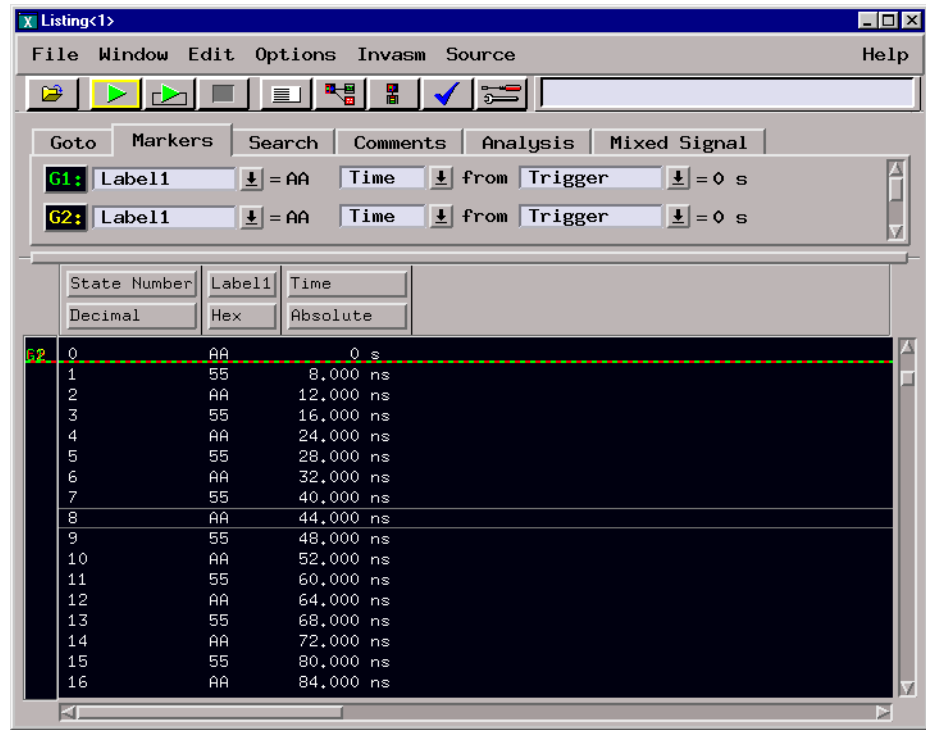

- b In the Marker Setup window, select the Define... field associated with G1, and the G1 Marker Pattern window appears. In the pattern field, enter “AA”. Select Apply, then select Close.

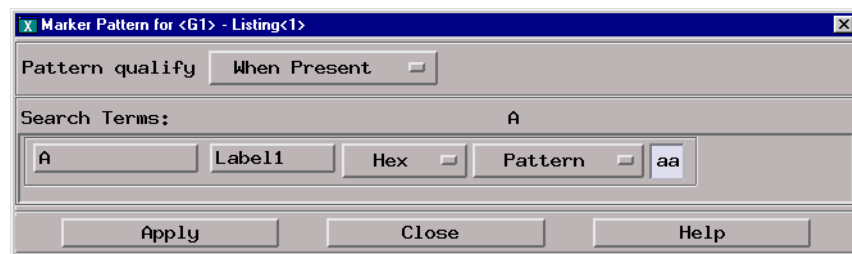

If the label selection field reads Label1\_TZ, you must select Label1 for the search term. To do this, select Label1\_TZ; then, in the popup menu, select Replace label. In the Replace popup menu, select Label1, then Apply, then Close.

- c In the Marker Setup window, select the Define... field associated with G2, and the G2 Marker Pattern window appears. In the pattern field, enter “55”. Select Apply, then select Close.

**To Test the Single-clock, Single-edge, State Acquisition**

If the Label selection field reads Label1\_TZ, you must select Label1 for the search term. Follow the same procedure as in b above.

- d** In the Marker Setup window, select the 'occurs' value field that corresponds to marker G1. Enter 4095.
- e** In the Marker Setup window, select the 'occurs' value field that corresponds to marker G2. Enter 4096.

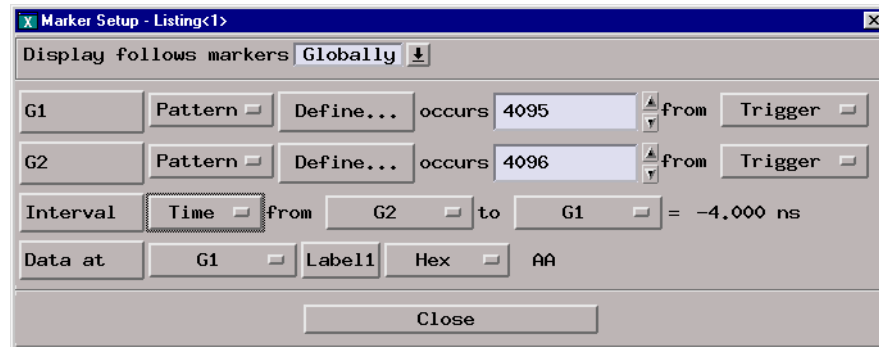

- f** Select Close to apply the marker values to the data. If the "Pattern NOT found for marker..." error message does not appear, then the test passes. Record the Pass or Fail in the performance test record.
- 6** Repeat steps 4 and 5 for the next clock edge listed in the table in step 4, until all listed clock edges have been tested.
  - 7** Enable the pulse generator channel 1 COMP (LED on).

- 8 Using the Delay mode of the pulse generator channel 1, position the pulses according to the setup/hold combination selected, +0.0 ps or -50 ps.
  - a On the Oscilloscope, select [Define meas] Define  $\Delta$ Time - Stop edge: falling.
  - b On the oscilloscope, select [Shift]  $\Delta$ Time. Select Start src: channel 1, then select [Enter] to display the setup time ( $\Delta$ Time(1)-(2)).
  - c Adjust the pulse generator channel 1 Delay until the pulses are aligned according to the setup time of the setup/hold combination selected, +0.0 ps or -50 ps.

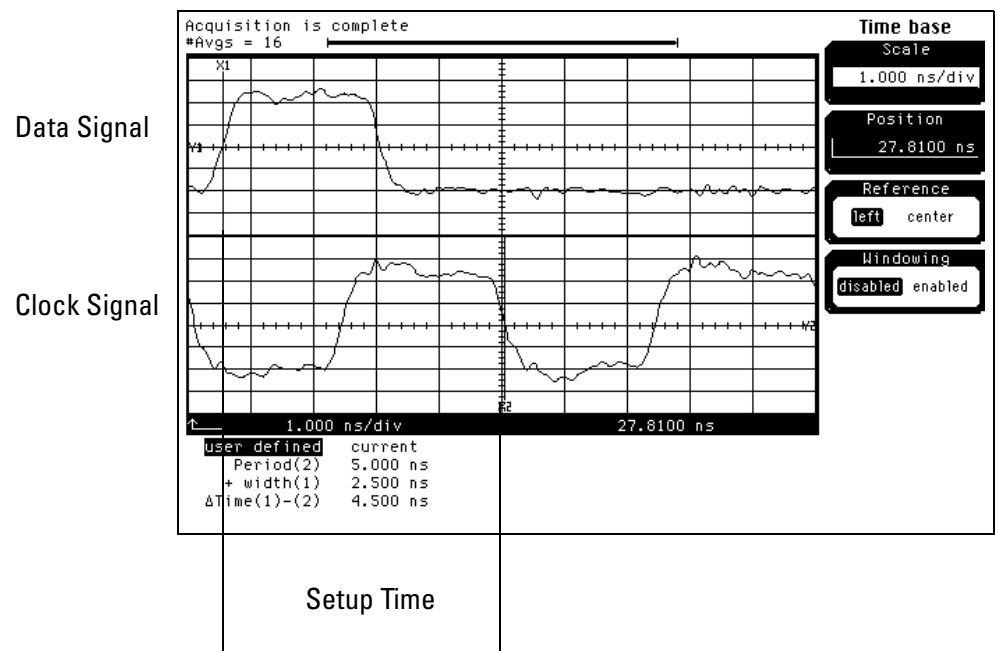

Disregard the Period(2) value. The settings provided in this procedure may measure the period from rising edge to rising edge, which is not a valid measurement.

- 9 Select the clock to be tested.
  - a In the Analyzer setup window, select the Sampling tab.
  - b Under the Sampling tab, select the clock edge field under the clock to be tested. Then select Falling Edge. The first time through this test, select the first clock and edge. Ensure all other clocks are turned off.

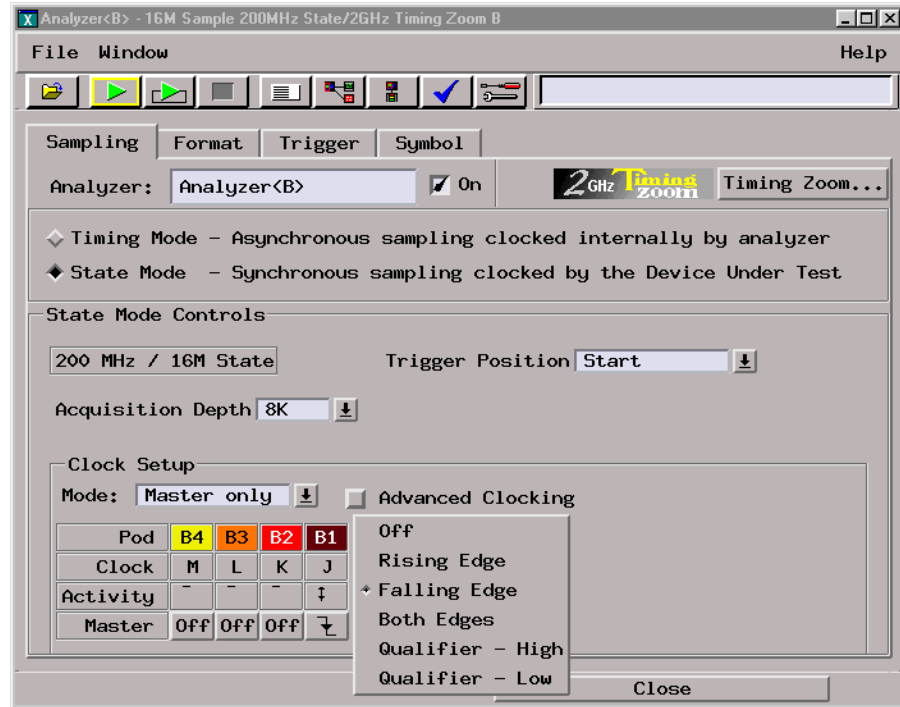

**Clocks**

J↓	K↓	L↓	M↓
----	----	----	----

- c Connect the clock input channel to be tested to the pulse generator channel 1 OUTPUT. Disconnect all other clock input channels.
- 10 Verify the test data.
  - a In the Listing window, select Run. The display should show an alternating pattern of “AA” and “55”.
  - b If the “Pattern NOT found for marker...” error message does not appear, then the test passes. Record the Pass or Fail in the performance test record.
- 11 Repeat steps 9 and 10 for the next clock edge listed in the table in step 9, until all listed clock edges have been tested.



- 12** If the setup/hold used for the previous steps was 4.5/-2.0 ns, repeat steps 1 through 11 using setup/hold -2.0/4.5 ns. If the setup/hold used for the previous steps was -2.0/4.5 ns, continue on with the next section.

## To Test the Multiple-clock, Multiple-edge, State Acquisition

Testing the multiple-clock, multiple-edge, state acquisition verifies the performance of the following specifications:

- Minimum master to master clock time
- Maximum state acquisition speed
- Setup/Hold time

This test checks a combination of data channels using multiple clocks at two selected setup/hold times.

### Equipment Required

Equipment	Critical Specifications	Recommended HP/Agilent Model/Part
Pulse Generator	200 Mhz, 3.0 ns pulse width, < 600 ps rise time	8133A option 003
Digitizing Oscilloscope	≥ 6 GHz bandwidth, < 58 ps rise time	54750A w/ 54751A
Adapter	SMA(m)-BNC(f)	1250-1200
SMA Coax Cable (Qty 3)		8120-4948
Coupler (Qty 3)	BNC (m-m)	1250-0216
BNC Test Connector, 6x2 (Qty 3)		

---

---

### Set up the equipment

- 1 If you have not already done so, do the procedure “To Set up the Test Equipment and the Analyzer” on page 38. Ensure that the pulse generator and oscilloscope are set up according to the tables in that section.
- 2 Change the pulse generator channel 2 width to 3.000 ns.

---

## Set up the logic analyzer

Perform the following steps if you have not already done so for the previous test.

- 1** Set up the Sampling tab.
  - a** In the Analyzer setup window, select the Sampling tab.
  - b** Select State Mode.
- 2** Assign all pods to Analyzer 1.
  - a** In the Analyzer setup window, select the Format tab.
  - b** Under the Format tab, select Pod Assignment.
  - c** In the Pod Assignment window, use the mouse to drag the pods to the Analyzer 1 column.

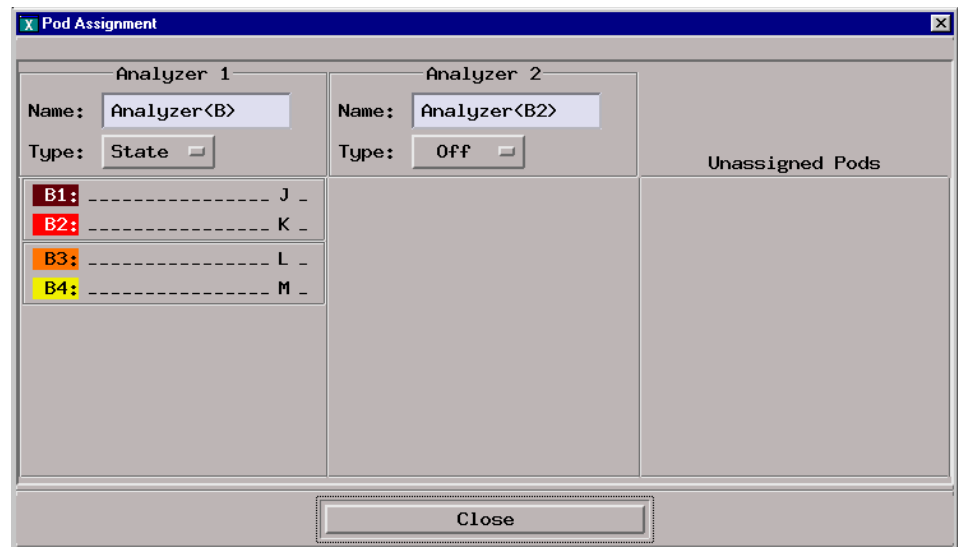

- d** Select Close to close the Pod Assignment window.

- 3** Set up the Format tab.
  - a** Under one of the pod fields, select TTL.
  - b** In the Pod Threshold window, ensure the Apply threshold setting to all pods checkbox is checked.
  - c** In the Pod Threshold window, select the Standard threshold voltage field. At the pop-up menu, select ECL (-1.30V).

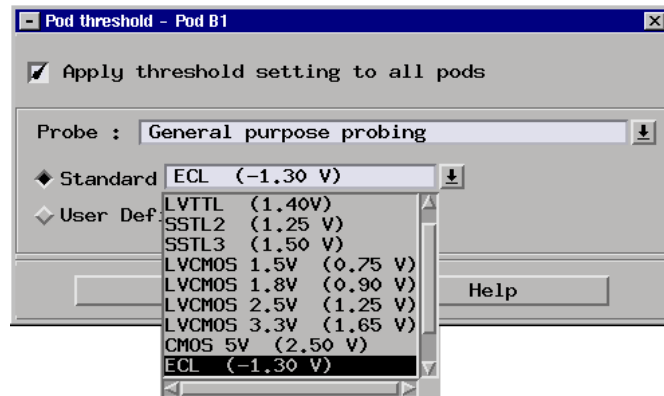

- d** Select Close to close the Pod Threshold window.

- 4 Set up the Trigger tab.
  - a In the Analyzer setup window, select the Trigger tab. Under the Trigger tab, select the Settings tab.
  - b Select the Acquisition Depth field, then select “8K”.
  - c Select the Trigger Position field, then select Start.

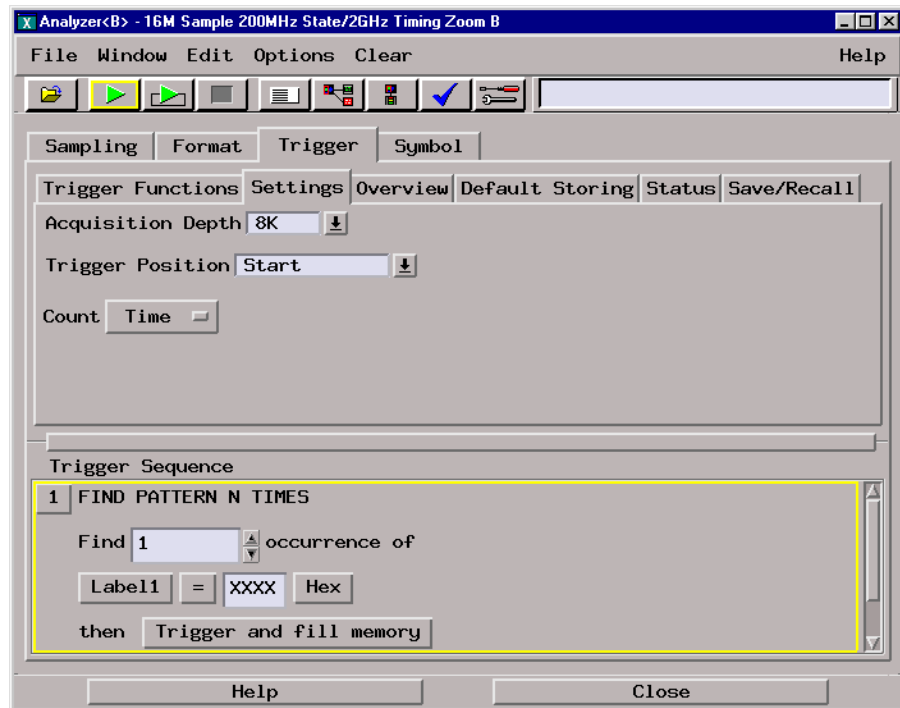

- 5 Set up the Listing window.
  - a In the Listing window, select the Markers tab.
  - b Select the G1: field and the Markers Setup window appears.
  - c Select the Time field associated with G1, and select Pattern. Select the Time field associated with G2, and select Pattern.

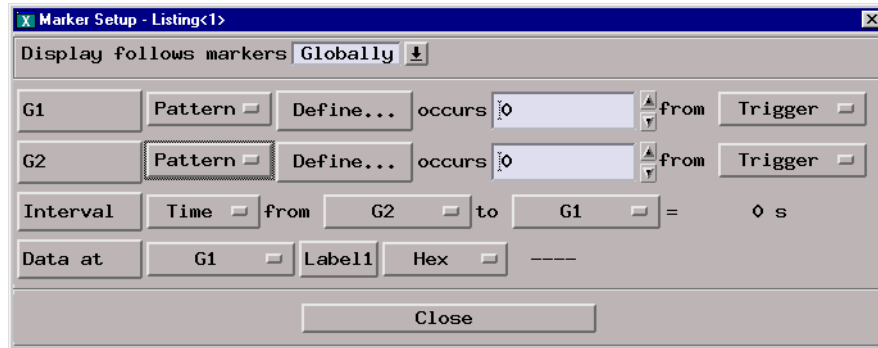

Note: Leave the Marker Setup window open. You will be entering numeric values in the “occurs” field after acquiring the test data.

## Connect the logic analyzer

- 1** Using the 6-by-2 test connectors, connect the logic analyzer clock and data channels listed in the following table to the pulse generator.
- 2** Using SMA cables, connect channel 1, channel 2, and trigger from the oscilloscope to the pulse generator according to the following illustration.

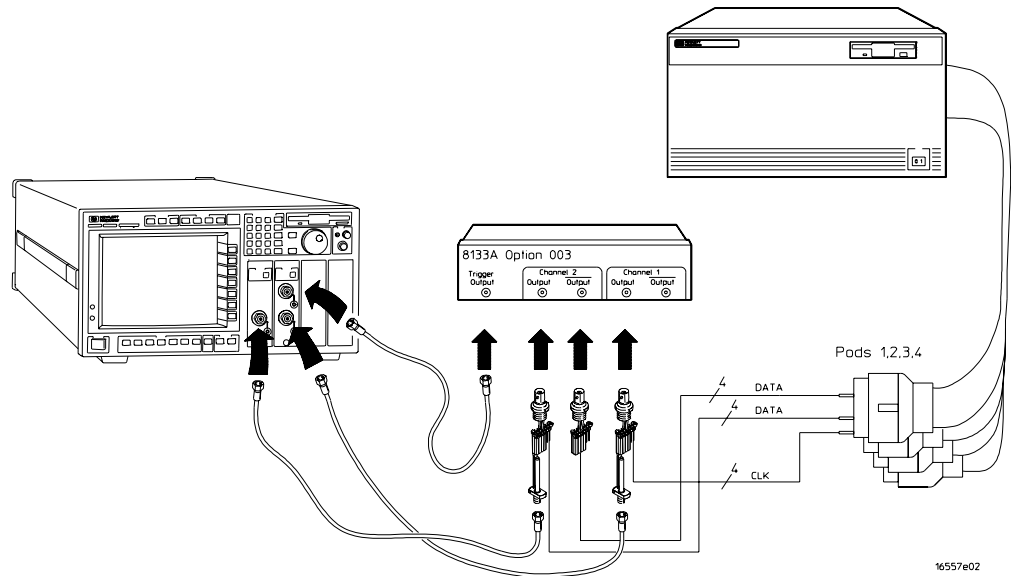

## Connect the 16740/41/42A to the Pulse Generator

8133A Ch2 Output	8133A Ch2 Output	8133A Ch1 Output
Pod 1 channel 3	Pod 1 channel 11	J-clock
Pod 2 channel 3	Pod 2 channel 11	K-clock
Pod 3 channel 3	Pod 3 channel 11	L-clock
Pod 4 channel 3	Pod 4 channel 11	M-clock

- 3** Activate the data channels that are connected according to the previous table.
  - a** In the Analyzer setup window, select the Format tab.
  - b** Under the Format tab, select the field showing the channel assignments for one of the pods being tested, then select Individual. Using the mouse, select the data channels to be tested (channels 11 and 3 of each pod). An asterisk means that a channel is turned on. Follow this step for the remaining pods to be tested.

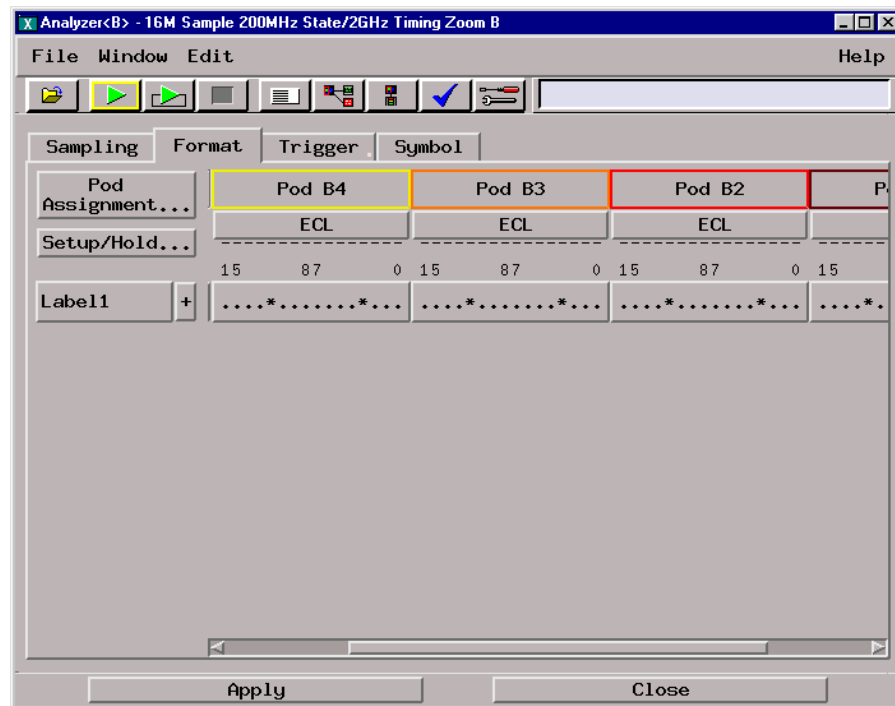



- 4 Configure the trigger pattern.
  - a Select the Trigger tab. Under the Trigger tab, select the Trigger Functions tab.
  - b In the General State field, select Store nothing until pattern occurs. Then select Replace.
  - c Under Trigger Sequence, locate the Label 1 = trigger pattern field. Enter “AA” in the trigger pattern field. The trigger function should now read Store nothing until Label 1 = AA Hex occurs then Trigger and fill memory.

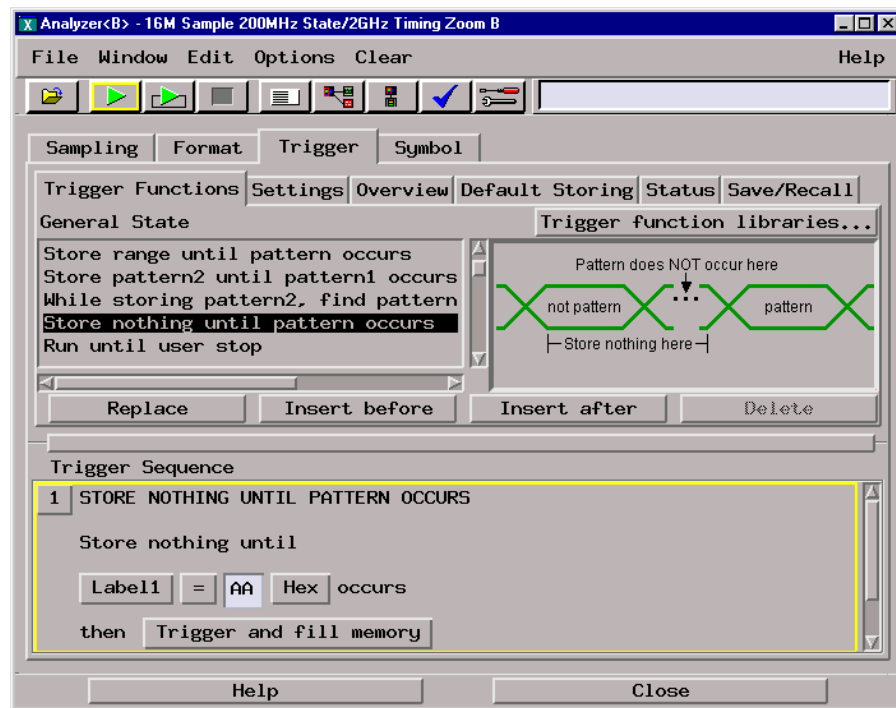

## Verify the test signal

- 1** Check the clock period. Using the oscilloscope, verify that the master-to-master clock time is 5.000 ns, +0 ps or -100 ps.
  - a** Turn on the pulse generator channel 1, channel 2, and trigger outputs.
  - b** In the oscilloscope Timebase menu, select Position. Using the oscilloscope knob, position the clock waveform so that a rising edge appears at the left of the display.
  - c** On the oscilloscope, select [Shift] Period: channel 2, then select [Enter] to display the clock period (Period(2)). If the period is more than 5.000 ns, go to step e. If the period is less than or equal to 5.000 ns but greater than 4.900 ns, go to step 2.
  - d** In the oscilloscope Timebase menu, increase Position 5.000 ns. If the period is more than 5.000 ns, decrease the pulse generator Period in 10 ps increments until one of the two periods measured is less than or equal to 5.000 ns but greater than 4.900 ns.

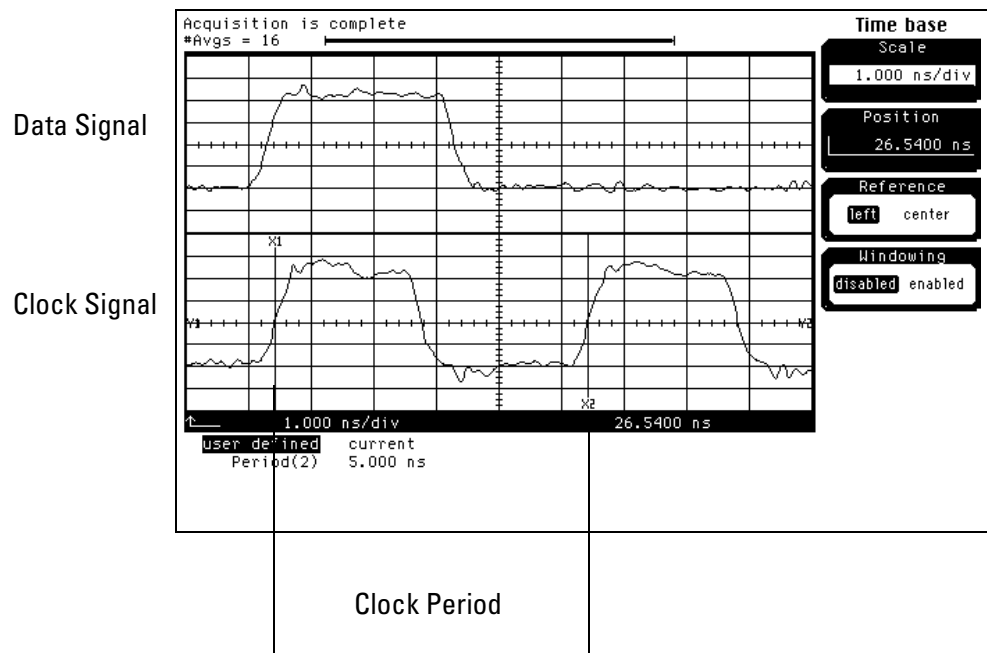

- 2 Check the data pulse width. Using the oscilloscope, verify that the data pulse width is 3.000 ns, +0 ps or - 50 ps.
  - a In the oscilloscope Timebase menu, select Position. Using the oscilloscope knob, position the data waveform so that the waveform is centered on the screen.
  - b On the oscilloscope, select [Shift] + width: channel 1, then select [Enter] to display the data signal pulse width (+ width (1)).
  - c If the pulse width is outside the limits, adjust the pulse generator channel 2 width until the pulse width is within limits.

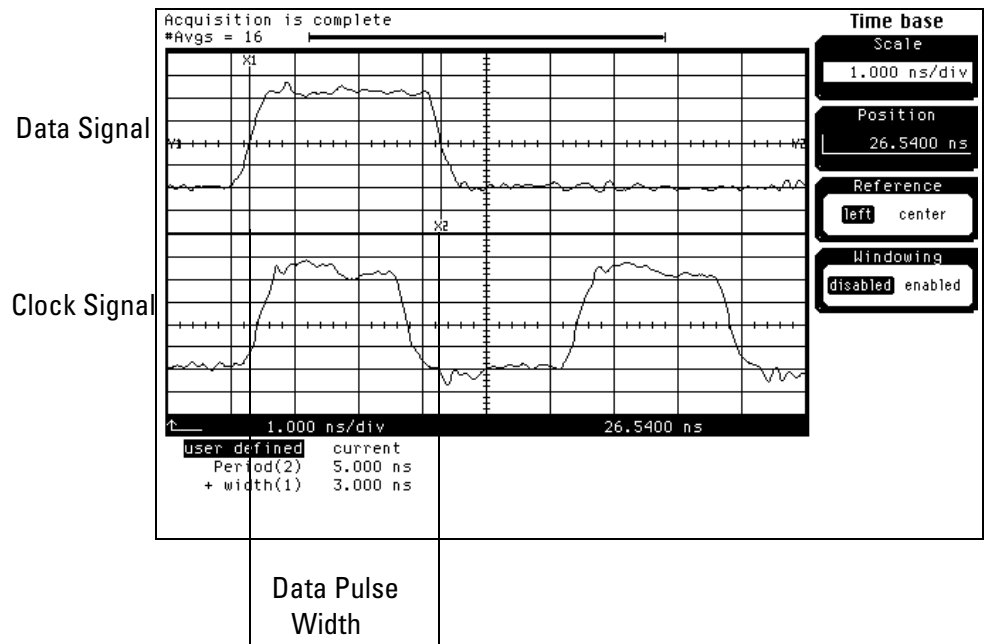

---

## Check the setup/hold with single clock edges, multiple clocks

- 1 Select the logic analyzer setup/hold time.
  - a In the Analyzer setup window, select the Sampling tab.
  - b Under the Sampling tab, select and activate any two clock edges.

You must have two single-edge clocks selected before the Setup/Hold window will allow a Setup/Hold of 5.0/-2.0 ns.
  - c Select the Format tab. Under the Format tab, select Setup/Hold.
  - d In the Setup and Hold window, ensure All bits is selected.
  - e Enter the setup time of the setup/hold combination to be tested in the Setup: field.

### Setup/Hold Combinations

5.0/-2.0 ns

-1.5/4.5 ns



- f Select the close (X) button in the upper-right corner to close the Setup/ Hold window.
- 2 Disable the pulse generator channel 1 COMP (LED off).

- 3** Using the Delay mode of the pulse generator channel 1, position the pulses according to the setup/hold combination selected, +0.0 ps or -50 ps.
  - a** On the Oscilloscope, select [Define meas] Define  $\Delta$  Time - Stop edge: rising.
  - b** In the oscilloscope timebase menu, select Position. Using the oscilloscope knob, position the rising edge of the clock waveform so that it is centered on the display.
  - c** On the oscilloscope, select [Shift]  $\Delta$  Time, then select [Enter] to display the setup time ( $\Delta$  Time(1)-(2)).
  - d** Adjust the pulse generator channel 1 Delay until the pulses are aligned according to the setup time of the setup/hold combination selected, +0.0 ps or -50 ps.

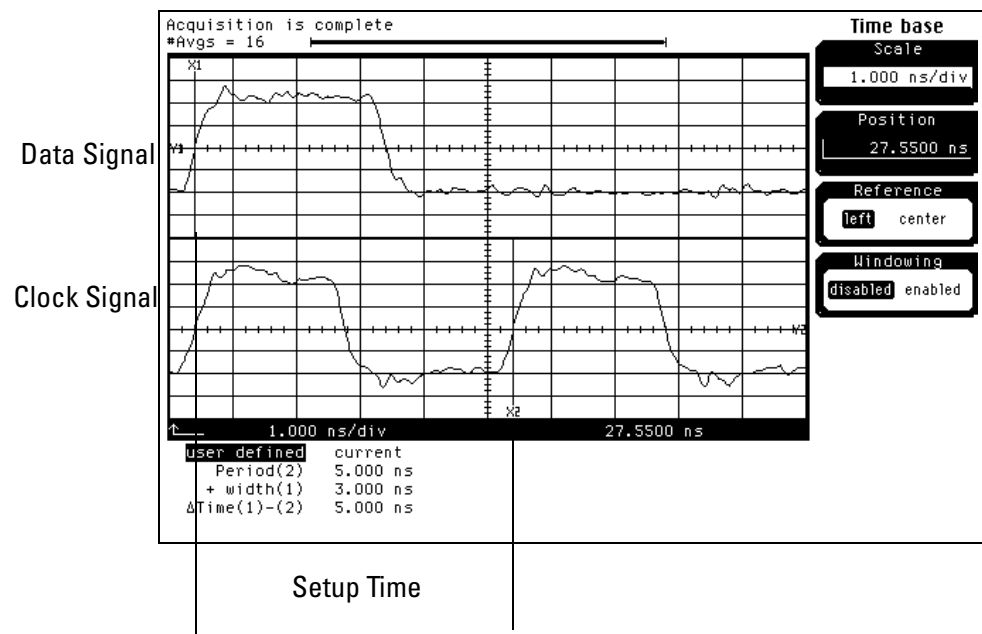

Disregard the Period(2) value. The settings provided in this procedure may measure the period from falling edge to falling edge, which is not a valid measurement.

- 4 Select the clock combination to be tested.
  - a In the Analyzer setup window, select the Sampling tab.
  - b Under the Sampling tab, select the clock edge field under each clock. Then select Rising Edge. The clock setup field should show  $J\uparrow + K\uparrow + L\uparrow + M\uparrow$ .

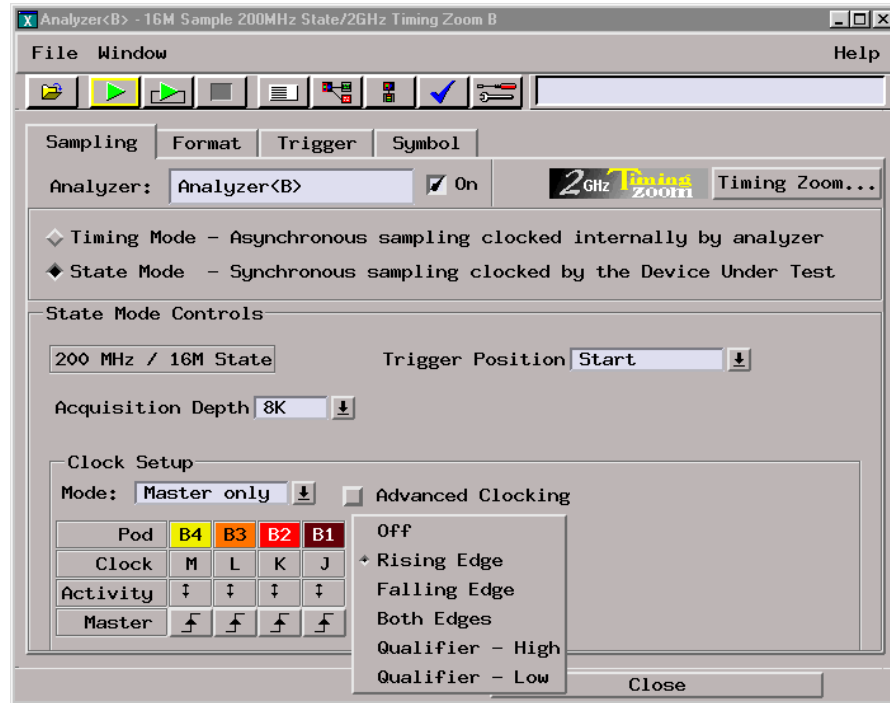

**5** Verify the test data.

- a** In the Listing window, select Run. The display should show an alternating pattern of “AA” and “55”.

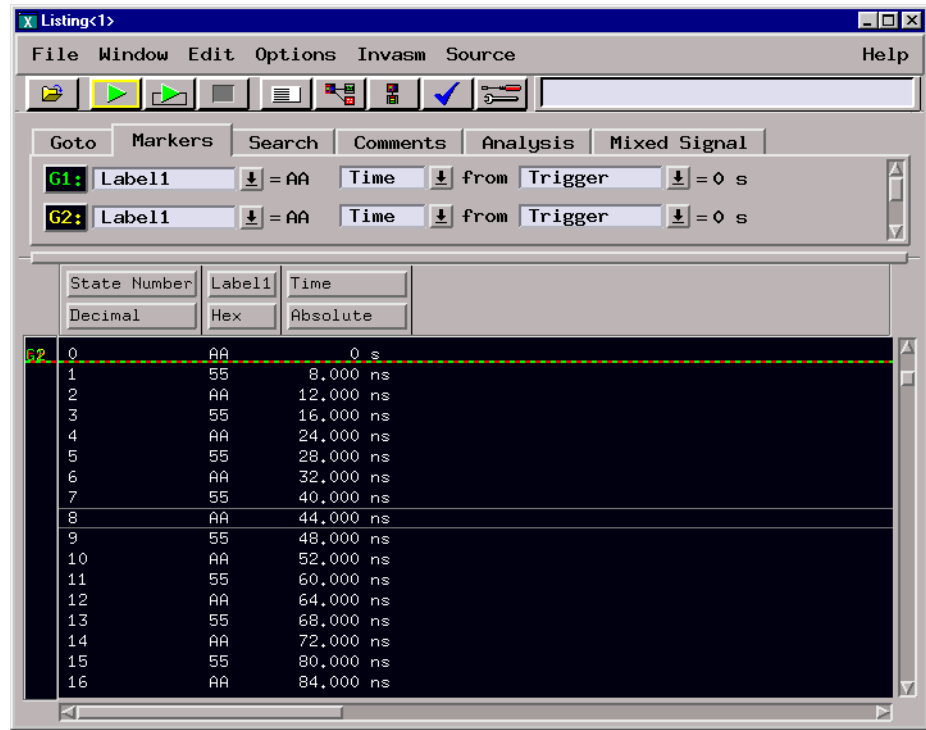

- b** In the Marker Setup window, select the Define... field associated with G1, and the G1 Marker Pattern window appears. In the pattern field, enter “AA”. Select Apply, then select Close.

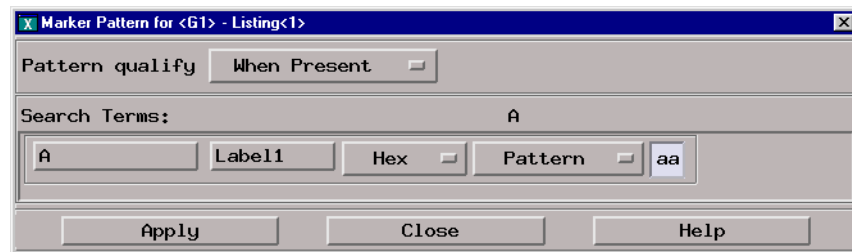

If the label selection field reads Label1\_TZ, you must select Label1 for the search term. To do this, select Label1\_TZ; then, in the popup menu, select Replace label. In the Replace popup menu, select Label1, then Apply, then Close.

- c** In the Marker Setup window, select the Define... field associated with G2, and the G2 Marker Pattern window appears. In the pattern field, enter “55”. Select Apply, then select Close.

**To Test the Multiple-clock, Multiple-edge, State Acquisition**

If the Label selection field reads Label1\_TZ, you must select Label1 for the search term. Follow the same procedure as in b above.

- d** In the Marker Setup window, select the 'occurs' value field that corresponds to marker G1. Enter 4095.
- e** In the Marker Setup window, select the 'occurs' value field that corresponds to marker G2. Enter 4096.

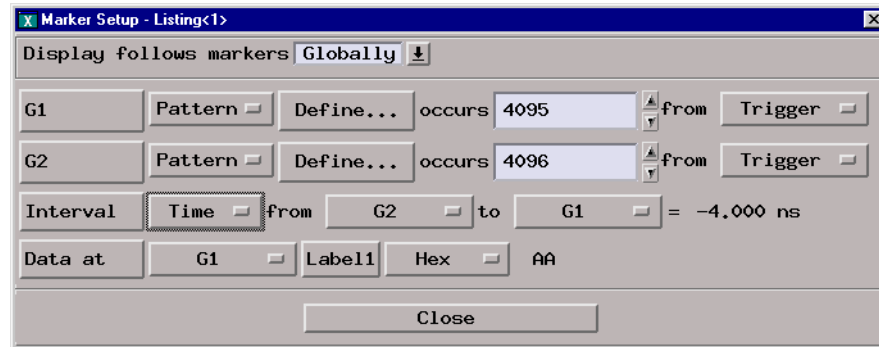

- f** Select Close to apply the marker values to the data. If the “Pattern NOT found for marker...” error message does not appear, then the test passes. Record the Pass or Fail in the performance test record.
- 6** Repeat steps 4 and 5 for the next clock edge combination listed in the table in step 4, until both clock combinations have been tested.
  - 7** Enable the pulse generator channel 1 COMP (LED on).



- 8 Using the Delay mode of the pulse generator channel 1, position the pulses according to the setup/hold combination selected, +0.0 ps or -50 ps.
  - a On the Oscilloscope, select [Define meas] Define  $\Delta$ Time - Stop edge: falling.
  - b On the oscilloscope, select [Shift]  $\Delta$ Time. Select Start src: channel 1, then select [Enter] to display the setup time ( $\Delta$ Time(1)-(2)).

Adjust the pulse generator channel 1 Delay until the pulses are aligned according to the setup time of the setup/hold combination selected, +0.0 ps or -50 ps.

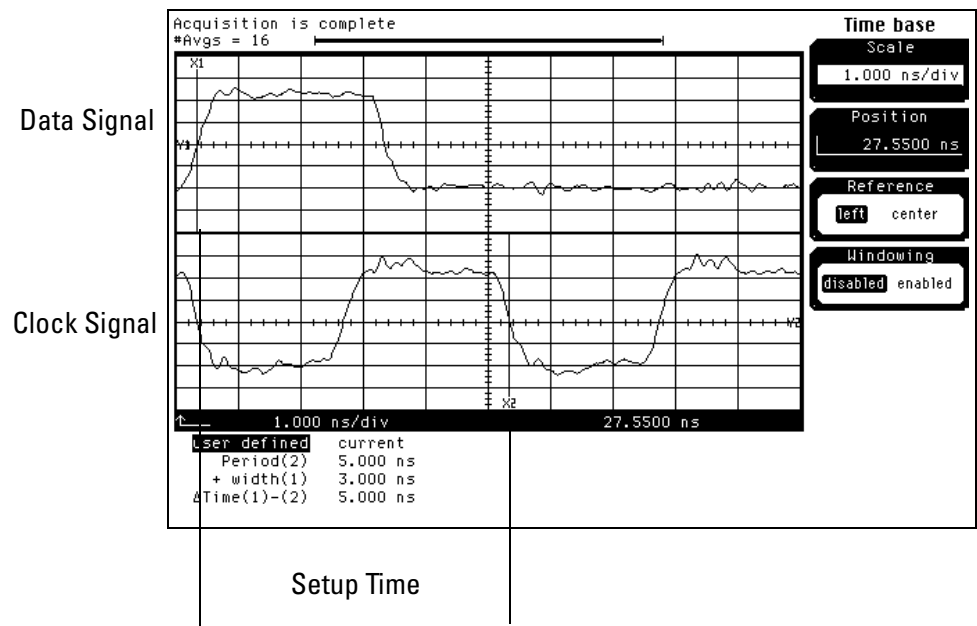

Disregard the Period(2) value. The settings provided in this procedure may measure the period from rising edge to rising edge, which is not a valid measurement.

- 9 Select the clock combination to be tested.
  - a In the Analyzer setup window, select the Sampling tab.
  - b Under the Sampling tab, select the clock edge field under each clock. Then select Falling Edge. The clock setup field should show J↓ + K↓ + L↓ + M↓.

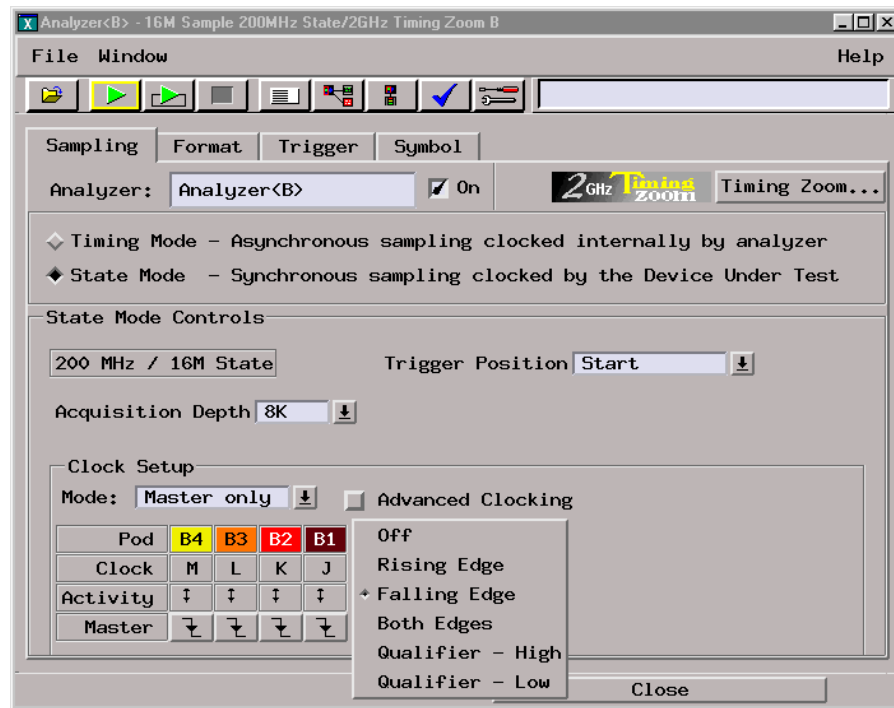

- 10 Verify the test data.
  - a In the Listing window, select Run. The display should show an alternating pattern of “AA” and “55”.
  - b If the “Pattern NOT found for marker...” error message does not appear, then the test passes. Record the Pass or Fail in the performance test record.
- 11 Repeat steps 9 and 10 for the next clock combination listed in the table in step 9, until both clock combinations have been tested.
- 12 If the setup/hold used for the previous steps was 5.0/-2.0 ns, repeat steps 1 through 11 using setup/hold -1.5/4.5 ns. If the setup/hold used for the previous steps was -1.5/4.5 ns, continue on with the next section.

---

## To Test the Single-clock, Multiple-edge, State Acquisition

Testing the single-clock, multiple-edge, state acquisition verifies the performance of the following specifications:

- Minimum master to master clock time
- Maximum state acquisition speed
- Setup/Hold time

This test checks a combination of data channels using a multiple-edge single clock at two selected setup/hold times.

### Equipment Required

Equipment	Critical Specifications	Recommended HP/Agilent Model/Part
Pulse Generator	200 Mhz, 3.0 ns pulse width, < 600 ps rise time	8133A option 003
Digitizing Oscilloscope	≥ 6 GHz bandwidth, < 58 ps rise time	54750A w/ 54751A
Adapter	SMA(m)-BNC(f)	1250-1200
SMA Coax Cable (Qty 3)		8120-4948
Coupler (Qty 3)	BNC (m-m)	1250-0216
BNC Test Connector, 6x2 (Qty 3)		

---

## Set up the equipment

- 1 If you have not already done so, do the procedure “To Set up the Test Equipment and the Analyzer” on page 38. Use the pulse generator settings listed below.
- 2 Make the following changes to the pulse generator configuration.

Timebase	Channel2
Period: 10.000 ns	Divide: PULSE ÷ 1 Width: 3.000 ns

## Set up the logic analyzer

Perform the following steps if you have not done so for the previous tests.

- 1** Set up the Sampling tab.
  - a** In the Analyzer window, select the Sampling tab.
  - b** Select State Mode.
- 2** Assign all pods to Analyzer 1.
  - a** In the Analyzer setup window, select the Format tab.
  - b** Under the Format tab, select Pod Assignment.
  - c** In the Pod Assignment window, use the mouse to drag the pods to the Analyzer 1 column.

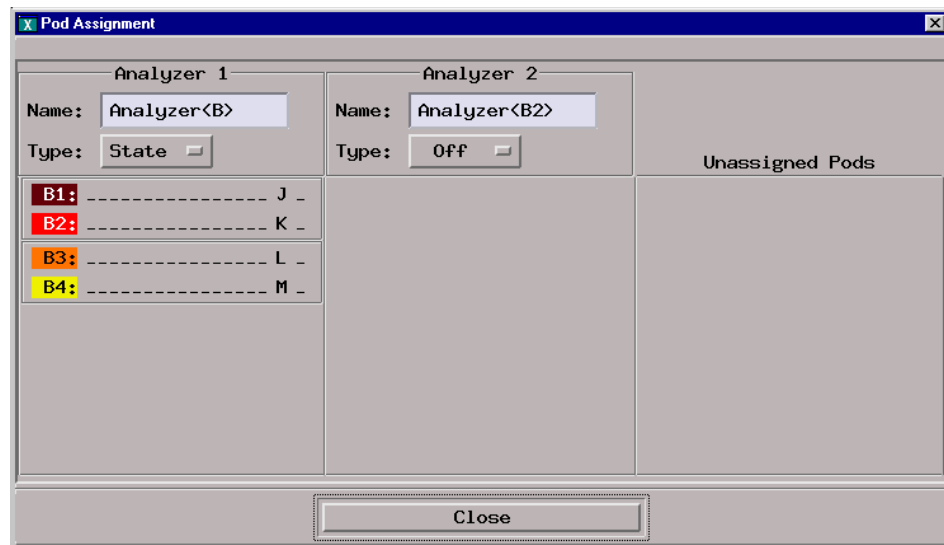

- d** Select Close to close the Pod Assignment window.

- 3** Set up the Format tab.
  - a** Under one of the pod fields, select TTL.
  - b** In the Pod Threshold window, ensure the Apply threshold setting to all pods checkbox is checked.
  - c** In the Pod Threshold window, select the Standard threshold voltage field. At the pop-up menu, select ECL (-1.30 V).

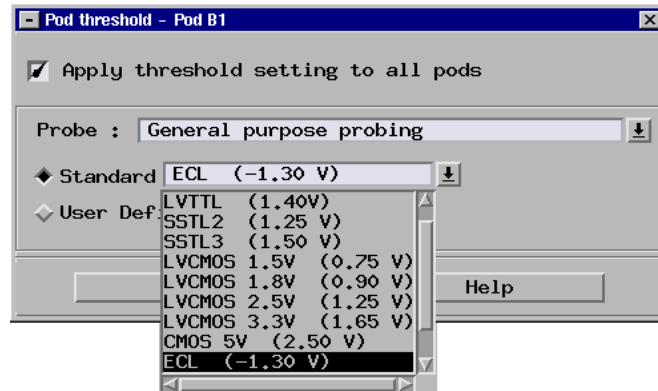

- d** Select Close to close the Pod Threshold window.

- 4 Set up the Trigger tab.
  - a In the Analyzer setup window, select the Trigger tab. Under the Trigger tab, select the Settings tab at the bottom of the window.
  - b Select the Acquisition Depth field, then select “8K”.
  - c Select the Trigger Position field, then select Start.

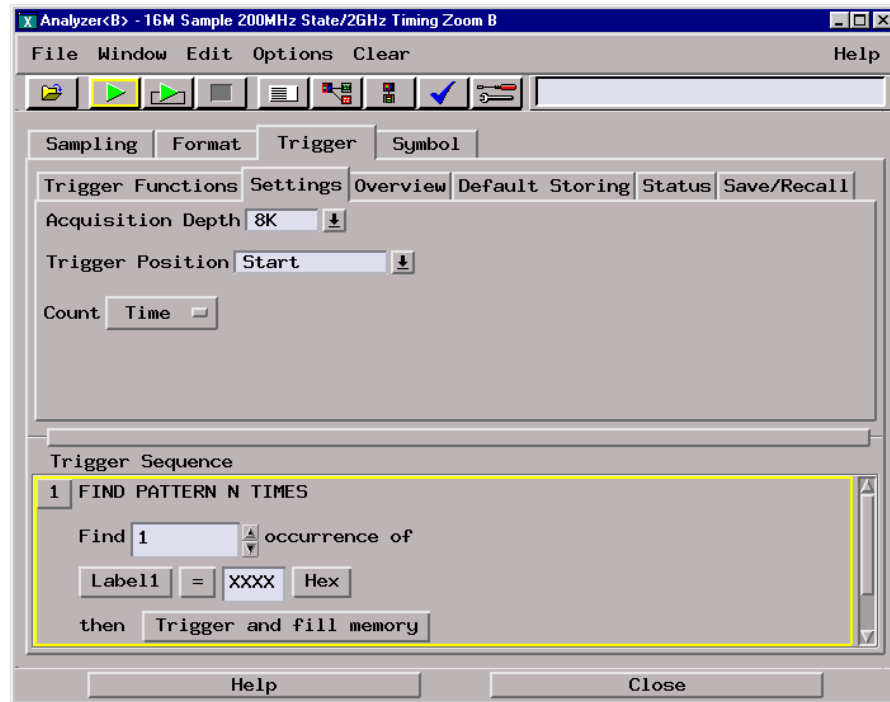

- 5 Set up the Listing window.
  - a In the Listing window, select the Markers tab.
  - b Select the G1: field and the Markers Setup window appears.
  - c Select the Sample field associated with G1, and select Pattern. Select the Sample field associated with G2, and select Pattern.

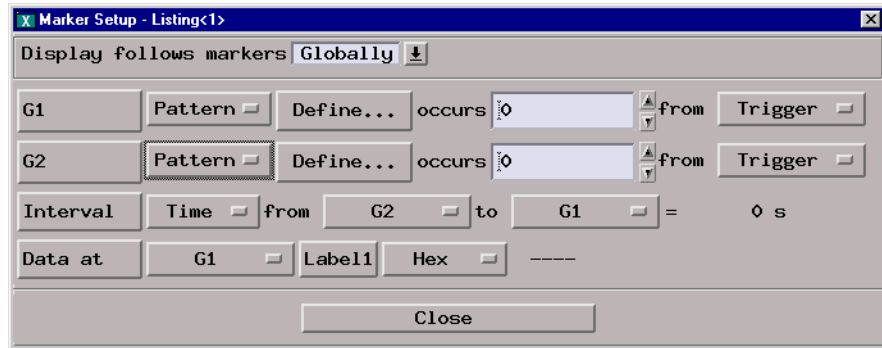

Note: Leave the Marker Setup window open. You will be entering numeric values in the “occurs” field after acquiring the test data.

## Connect the logic analyzer

- 1 Using the 6-by-2 test connectors, connect the logic analyzer clock and data channels listed in the following tables to the pulse generator.
- 2 Using SMA cables, connect channel 1, channel 2, and trigger from the oscilloscope to the pulse generator according to the following illustration.

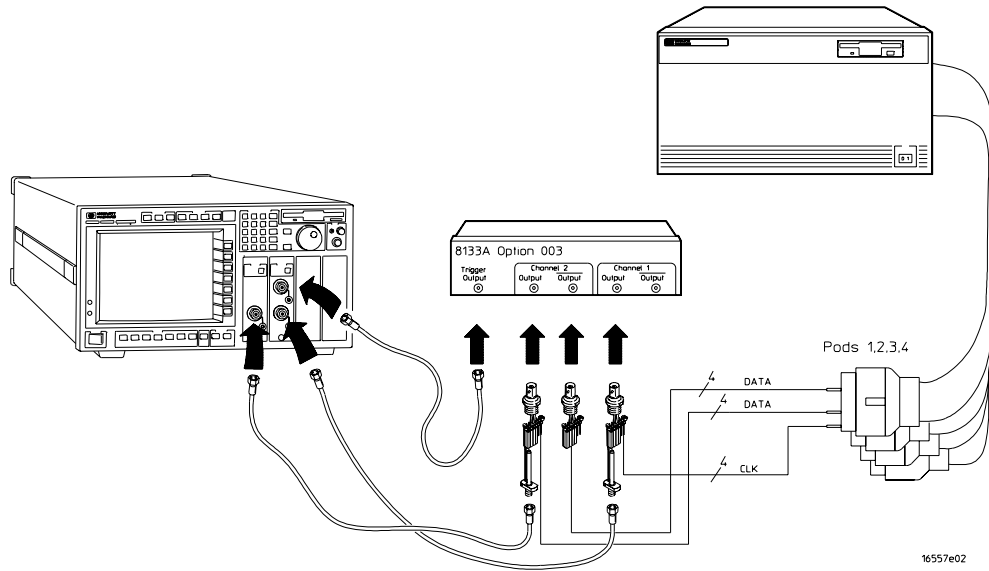

## Connect the 16740/41/42A to the Pulse Generator

8133A Ch2 Output	8133A Ch2 Output	8133A Ch1 Output
Pod 1 channel 3	Pod 1 channel 11	J-clock
Pod 2 channel 3	Pod 2 channel 11	
Pod 3 channel 3	Pod 3 channel 11	
Pod 4 channel 3	Pod 4 channel 11	



- 3** Activate the data channels that are connected according to the previous table.
  - a** In the Analyzer setup window, select the Format tab.
  - b** Under the Format tab, select the field showing the channel assignments for one of the pods being tested, then select Individual. Using the mouse, select the data channels to be tested (channels 11 and 3 of each pod). An asterisk means that a channel is turned on. Follow this step for the remaining pods to be tested.

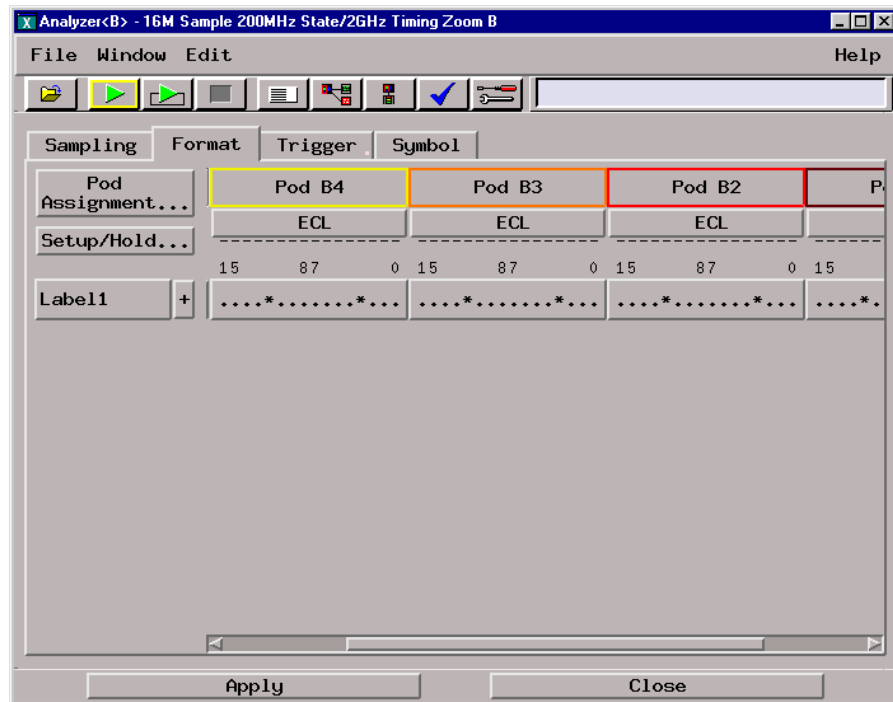

- 4 Configure the trigger pattern.
  - a Select the Trigger tab. Under the Trigger tab, select the Trigger Functions tab.
  - b In the General State field, select Store nothing until pattern occurs. Then select Replace.
  - c Under Trigger Sequence, locate the Label 1 = trigger pattern field. Enter “AA” in the trigger pattern field. The trigger function should now read Store nothing until Label 1 = AA Hex occurs then Trigger and fill memory.

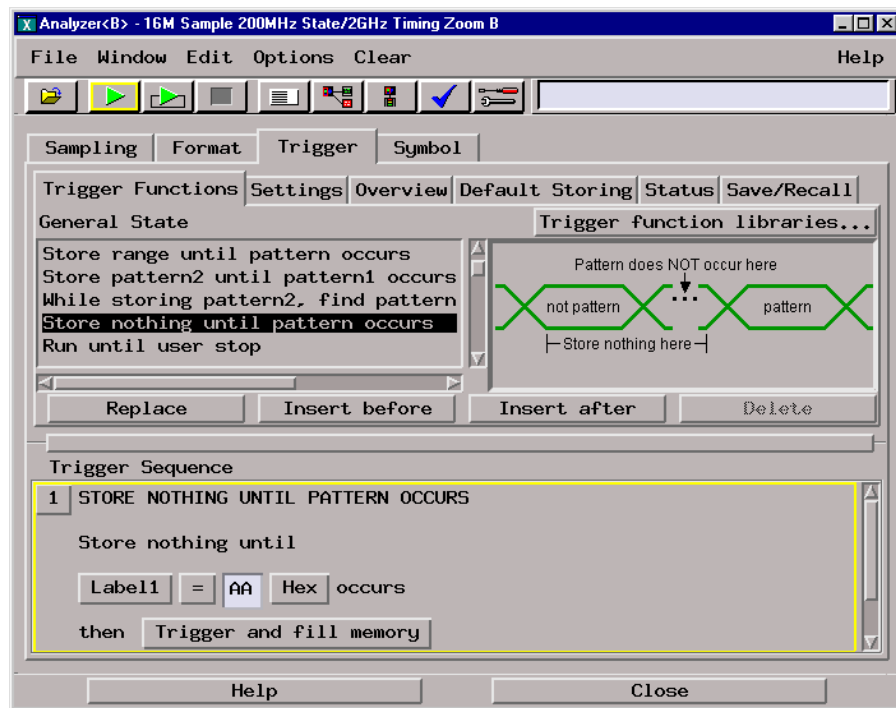

## Verify the test signal

- 1** Check the clock interval. Using the oscilloscope, verify that the master-to-master clock time is 5.000 ns, +0 ps or -100 ps.
  - a** Turn on the pulse generator channel 1, channel 2, and trigger outputs.
  - b** In the oscilloscope Timebase menu, select Scale: 2.000 ns/div.
  - c** In the oscilloscope Timebase menu, select Position. Using the oscilloscope knob, position the clock waveform so that a rising edge appears at the left of the display.
  - d** On the oscilloscope, select [Shift] + width: channel 2, then select [Enter] to display the master-to-master clock time (+ width(2)). If the positive-going pulse width is more than 5.000 ns, go to step e. If the positive-going pulse width is less than or equal to 5.000 ns but greater than 4.900 ns, go to step 2.
  - e** On the oscilloscope, select [Shift] - width: channel 2, then select [Enter] (- width(2)). If the negative pulse width is less than or equal to 5.000 ns but greater than 4.900 ns, go to step 2.
  - f** Decrease the pulse generator Period in 10-ps increments until the oscilloscope + width (2) or - width (2) read less than or equal to 5.000 ns, but greater than 4.900 ns.

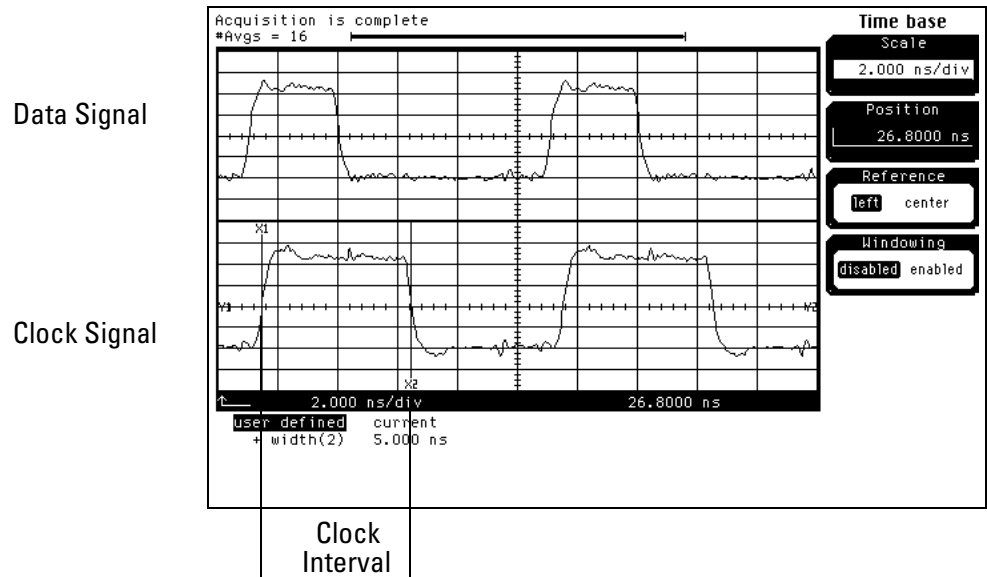

Chapter 3: Testing Performance  
To Test the Single-clock, Multiple-edge, State Acquisition

- 2 Check the data pulse width. Using the oscilloscope, verify that the data pulse width is 3.000 ns, +0 ps or -50 ps.
  - a In the oscilloscope Timebase menu, select Scale: 1.000 ns/div.
  - b In the oscilloscope Timebase menu, select Position. Using the oscilloscope knob, position the data waveform so that the waveform is centered on the screen.
  - c On the oscilloscope, select [Shift] + width: channel 1, then select [Enter] to display the data signal pulse width (+ width(1)).
  - d If the pulse width is outside the limits, adjust the pulse generator channel 2 width until the pulse width is within limits.

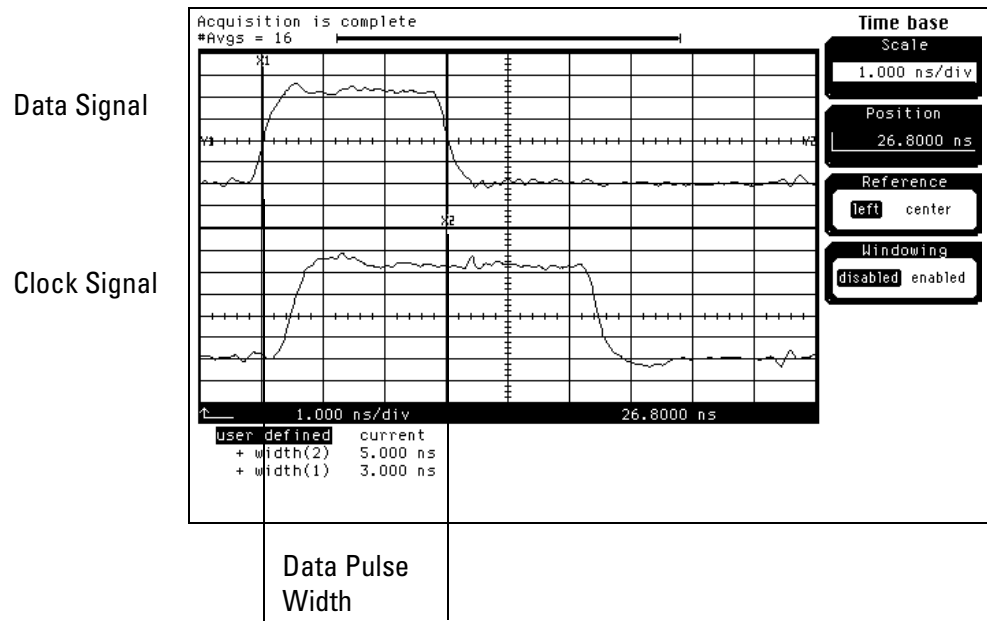

---

## Check the setup/hold with single clock, multiple clock edges

- 1 Select the logic analyzer setup/hold time.
  - a In the Analyzer setup window select the Sampling tab.
  - b Under the Sampling tab, select and activate a rising and falling edge for any clock.

The Setup/Hold window requires a double clock edge before it will allow a setup/hold of 5.0/-2.0 ns.

- c Select the Format tab. Under the Format tab, select Setup/Hold.
    - d In the Setup and Hold window, ensure All bits is selected.
    - e Enter the setup time of the setup/hold combination to be tested in the Setup: field.

### Setup/Hold Combinations

5.0/-2.0 ns  
-1.5/4.5 ns

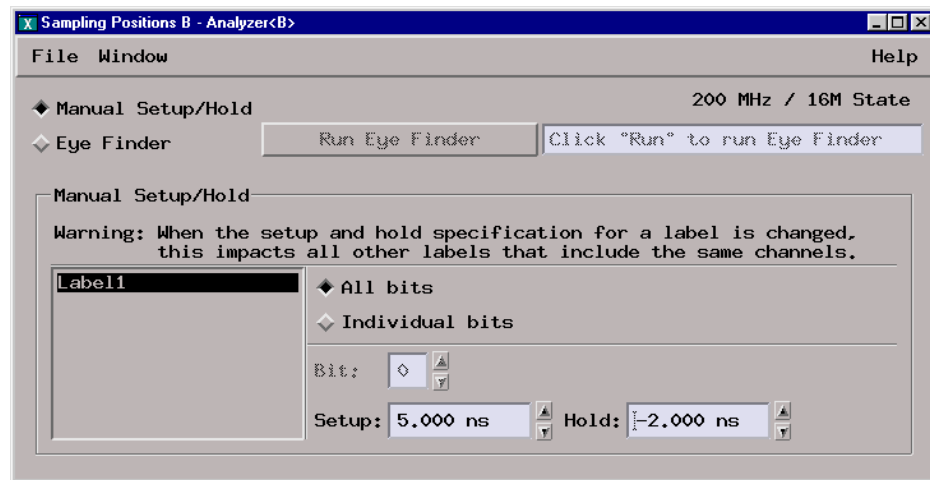

- f Select the close (X) button in the upper-right corner to close the Setup/Hold window.

**To Test the Single-clock, Multiple-edge, State Acquisition**

- 2** Using the Delay mode of the pulse generator channel 1, position the pulses according to the setup/hold combination selected, +0.0 ps or -50 ps.
  - a** On the Oscilloscope, select [Define meas] Define  $\Delta$  Time - Stop edge: rising.
  - b** In the oscilloscope timebase menu, select Position. Using the oscilloscope knob, position the falling edge of the data waveform so that it is centered on the display.
  - c** On the oscilloscope, select [Shift]  $\Delta$  Time. Select Start src: channel 1, then select [Enter] to display the setup time ( $\Delta$  Time(1)-(2)).
  - d** Adjust the pulse generator channel 2 Delay until the pulses are aligned according the setup time of the setup/hold combination selected, +0.0 ps or -50 ps.

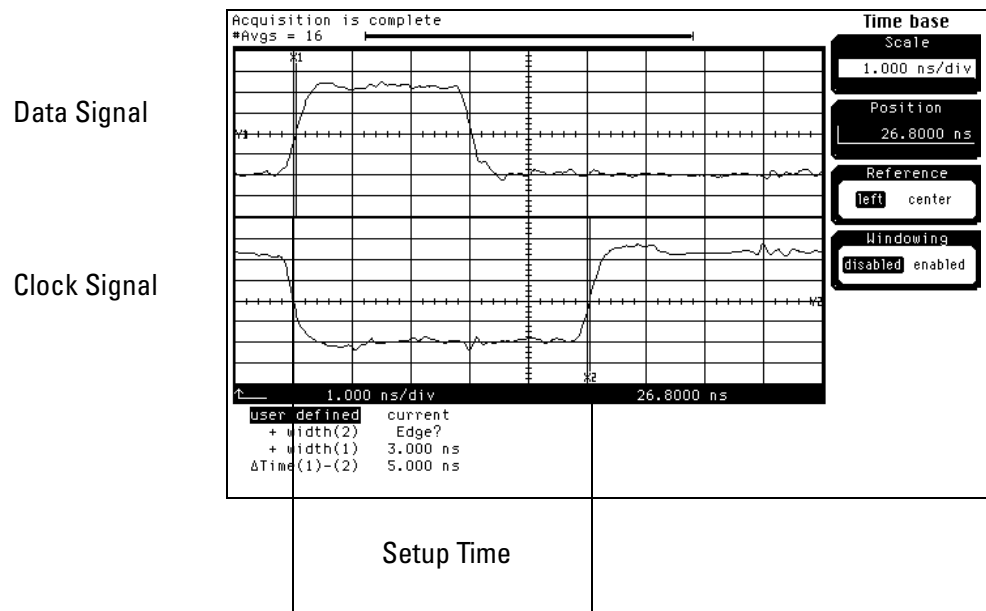

- 3** Select the clock to be tested.
  - a** In the Analyzer setup window, select the Sampling tab.
  - b** Under the Sampling tab, select the clock edge field under the clock to be tested. Then select Both Edges.

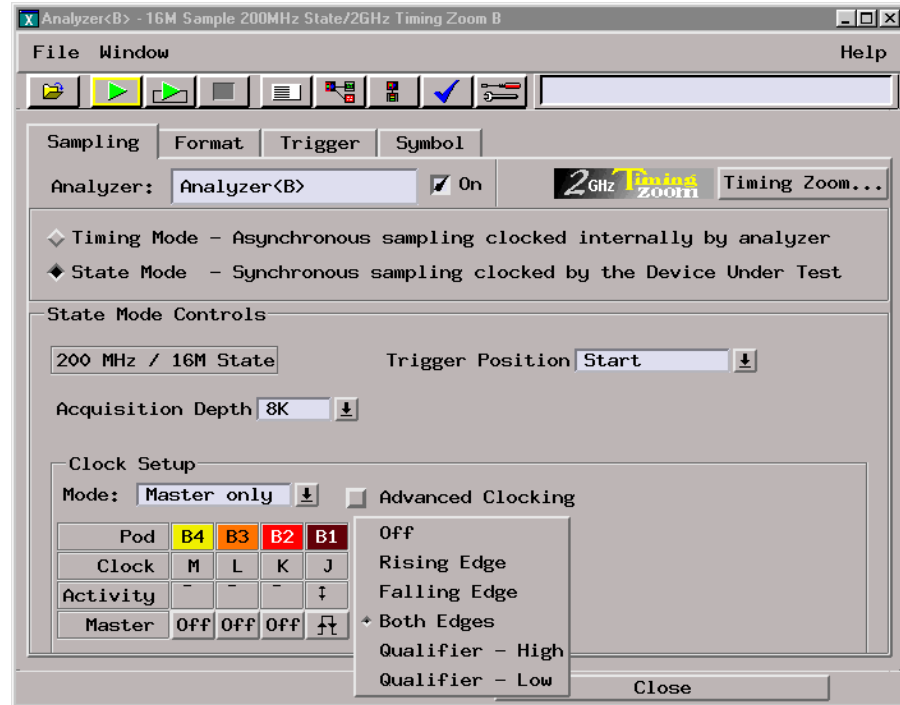

**Clocks**

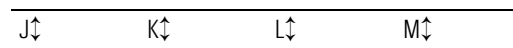

- c** Connect the clock input channel to be tested to the pulse generator channel 1 OUTPUT. Disconnect all other clock input channels.

- 4 Verify the test data.
  - a In the Listing window, select Run. The display should show an alternating pattern of “AA” and “55”.

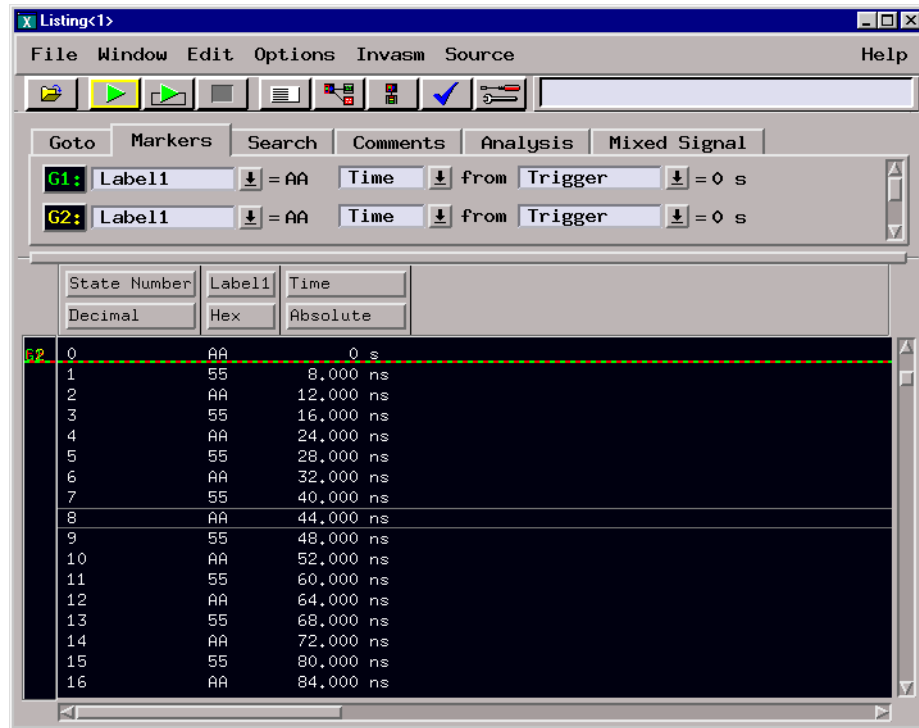

- b In the Marker Setup window, select the Define... field associated with G1, and the G1 Marker Pattern window appears. In the pattern field, enter “AA”. Select Apply, then select Close.

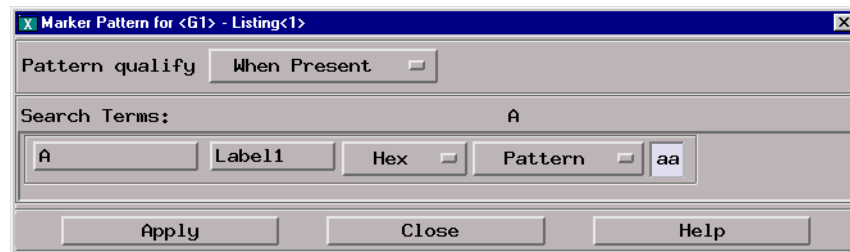

If the label selection field reads Label1\_TZ, you must select Label1 for the search term. To do this, select Label1\_TZ; then, in the popup menu, select Replace label. In the Replace popup menu, select Label1, then Apply, then Close.

- c In the Marker Setup window, select the Define... field associated with G2, and the G2 Marker Pattern window appears. In the pattern field, enter “55”. Select Apply, then select Close.



If the Label selection field reads Label1\_TZ, you must select Label1 for the search term. Follow the same procedure as in b above.

- d In the Marker Setup window, select the 'occurs' value field that corresponds to marker G1. Enter 4095.
- e In the Marker Setup window, select the 'occurs' value field that corresponds to marker G2. Enter 4096.



- f Select Close to apply the marker values to the data. If the "Pattern NOT found for marker..." error message does not appear, then the test passes. Record the Pass or Fail in the performance test record.
- 5 Repeat steps 3 and 4 for the next clock edge listed in the table in step 3, until all listed clock edges have been tested.
  - 6 If the setup/hold used for the previous steps was 5.0/-2.0 ns, repeat steps 1 through 5 using setup/hold -1.5/4.5 ns. If the setup/hold used for the previous steps was -1.5/4.5 ns, continue on with the next section.

---

## To Test the Time Interval Accuracy

Testing the time interval accuracy does not check a specification, but does check the following:

- 125 MHz oscillator

This test verifies that the 125-MHz timing acquisition synchronizing oscillator is operating within limits.

### Equipment Required

Equipment	Critical Specifications	Recommended HP/Agilent Model/Part
Pulse Generator	200 MHz < 600 ps rise time	8133A Option 003
Function Generator	Accuracy $\leq (5)(10^{-6}) \times$ frequency	8656B Option 002
SMA Coax Cable	18 GHz Bandwidth	8120-4948
BNC Cable		8120-1840
Adapter	SMA(m)-BNC(f)	1250-1200
Adapter	BNC(m)-SMA(f)	1250-2015
Coupler	BNC(m-m)	1250-0216
BNC Test Connector, 6x2		

---

## Set up the equipment

- 1 If you have not already done so, do the procedure “To Set up the Test Equipment and the Analyzer” on page 38.
- 2 Set up the pulse generator according to the following table.

### Pulse Generator Setup

Timebase	Channel 2	Trigger
Mode: Ext Period: 25.000 ns	Mode: Square Delay: 0.000 ns High: -0.90 V Low: -1.70 V COMP: Disabled (LED Off)	Divide: Divide $\div$ 1 Ampl: 0.50 V Offs: 0.00 V

3 Set up the function generator according to the following table.

**Function Generator Setup**

Freq: 40.000 00 MHz	Amptd: 1.00 V	Modulation: Off
---------------------	---------------	-----------------

---

**Set up the logic analyzer**

- 1 Set up the Sampling tab.
  - a In the Analyzer setup window, select the Sampling tab.
  - b Select Timing Mode.
  - c In Timing Mode Controls, select Trigger Position. Then select Start.
  - d Select the Acquisition Depth field. Then select “512K”.
  - e Select the sample period field. Then enter 2.5 ns.

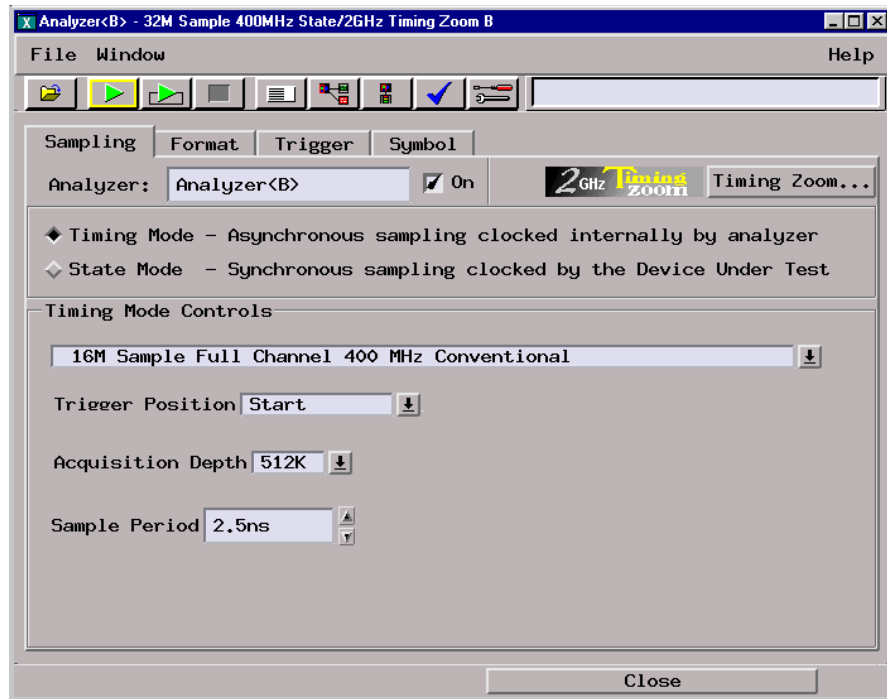

- 2 Set up the Format tab.
  - a In the Analyzer setup window, select the Format tab.
  - b Under the Format tab, select Pod Assignment.
  - c In the Pod Assignment window, use the mouse to drag Pods 1 and 2 to the Analyzer 1 column. Use the mouse to drag pods 3 and 4 to the Unassigned column.
  - d Select Close to close the Pod Assignment window.

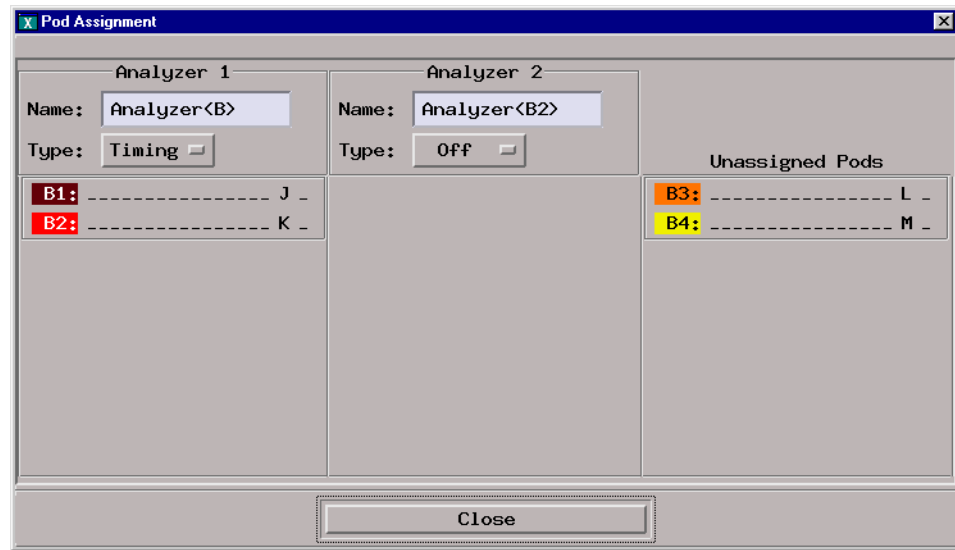

- e Under the Format tab, select the field showing the channel assignments for Pod 1. Using the mouse, first clear the channels (all “.”), then select channel 0. An asterisk means that the channel is turned on.
    - f Select the Threshold field under Pod1. Click on the checkbox next to Apply Threshold Settings to all pods to deselect.



- g** In the Pod Threshold window, select the Standard threshold voltage field. At the pop-up menu select ECL (-1.30 V).

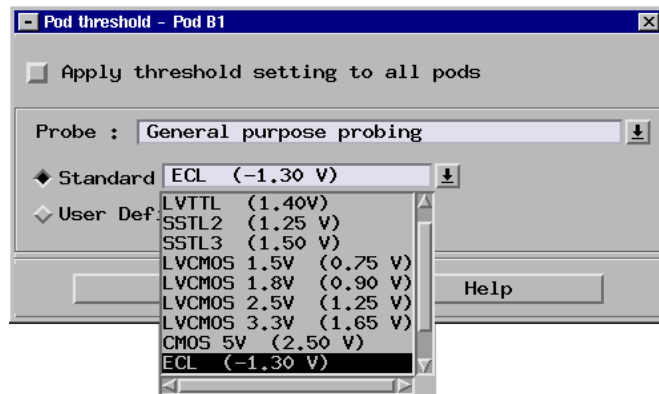

**3** Set up the Waveform window.

- a** In the Analyzer setup window, select Window, then select Slot n: Analyzer<n> (where “n” is the slot you have the module installed), then select Waveform. A Waveform window opens.
- b** In the Waveform window select the Markers tab.
- c** Select the G1 field and a Marker Setup window appears.
- d** Ensure that the Interval Time field reads “from G1 to G2” (instead of “from G2 to G1”).

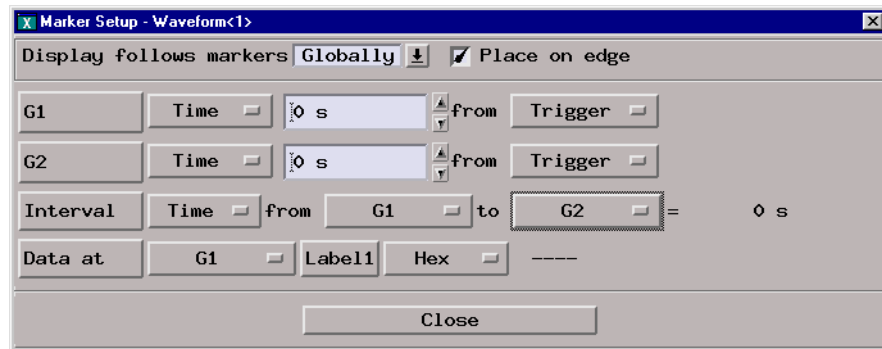

Leave this window open as you will be using it later when acquiring data.

---

## Connect the logic analyzer

- 1 Using a 6-by-2 test connector, connect channel 0 of Pod 1 to the pulse generator channel 2 output.
- 2 Using the SMA cable and the BNC adapter, connect the External Input of the pulse generator to the Main Signal of the function generator.

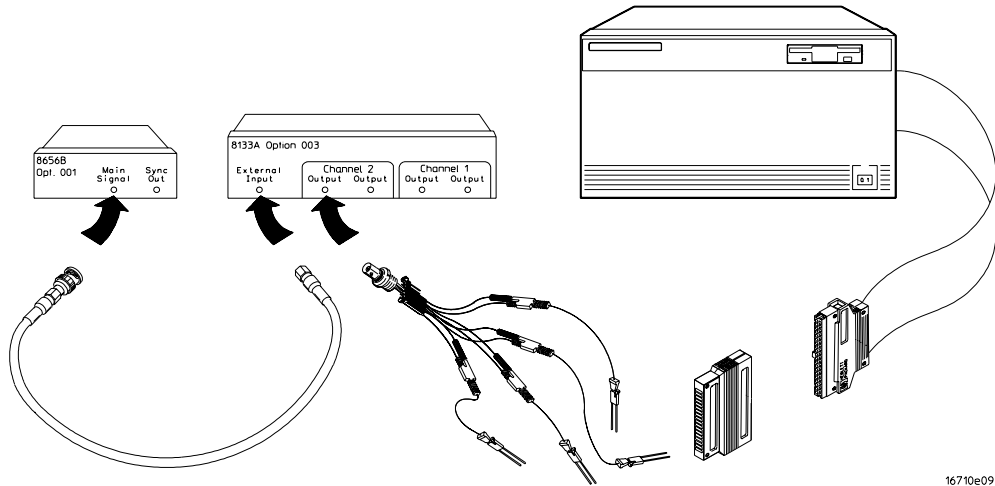

---

## Acquire the data

- 1 Enable the pulse generator channel 2 and trigger outputs (with the LED off).
- 2 In the logic analyzer Waveform window, select Run.

- 3** Configure the Markers to measure the time interval.
  - a** In the Marker Setup window select the Time field associated with G1, and select Pattern. Select the Time field associated with G2, and select Pattern.
  - b** Select the Occurs field associated with G1 and enter “1”. Select the Occurs field associated with G2 and enter “30000”.
  - c** Select the From field associated with G2 and select G1.

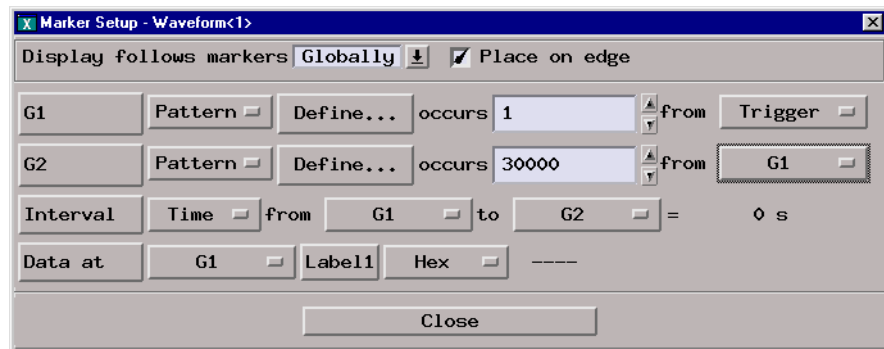

In the Marker Setup Window, you will observe the Interval Time from G1 to G2=value to determine the pass or fail status of this test.

- d** In the marker Setup window, select the Define... field associated with G1, and the G1 Marker Pattern window appears. In the Pattern field, enter “1”.

Select the Pattern Qualify field and select When Entering.

If the label selection field reads Label1\_TZ, you must select Label1 for the search term. To do this, select Label1\_TZ; then, in the popup menu, select Replace label. In the Replace popup menu, select Label1, then Apply, then Close.

In the Marker Pattern window, select Apply, then select Close.

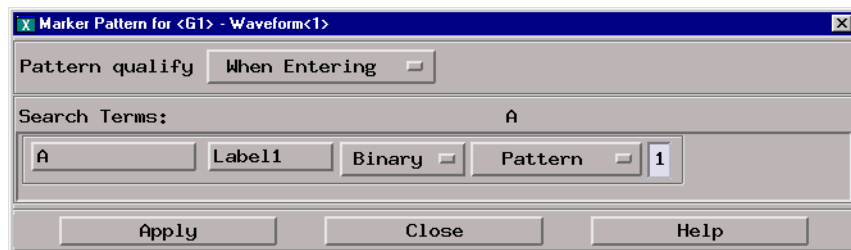

Chapter 3: Testing Performance  
To Test the Time Interval Accuracy

- e In the marker Setup window, select the Define... field associated with G2, and the G2 Marker Pattern window appears. In the Pattern field, enter "1".

Select the Pattern Qualify field and select When Entering.

If the Label selection field reads Label1\_TZ, you must select Label1 for the search term. Follow the same procedure as in b above.

In the Marker Pattern window, select Apply, then select Close.

4 Acquire the data.

- a In the Waveform window, move the mouse cursor over Run and click and hold the right mouse button. At the pop-up menu, select Repetitive.
- b Select Run. The logic analyzer repetitively acquires data.
- c Continuously observe the Interval Time from G1 to G2=value in the Marker Setup window.

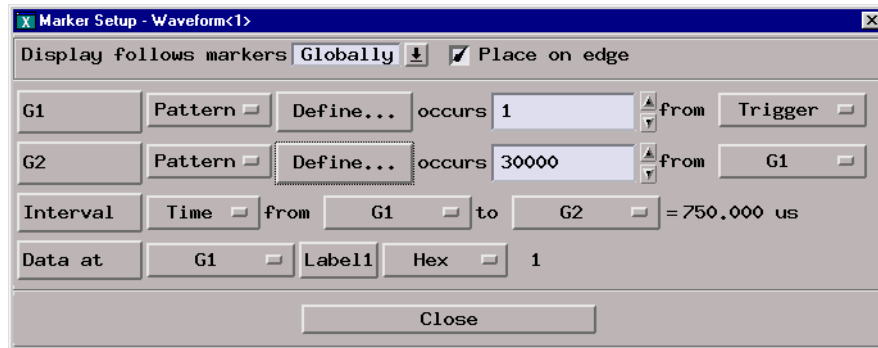

Allow the logic analyzer to run repetitively for approximately one minute. If the Interval Time value remains inside the range 749.921  $\mu$ s to 750.079  $\mu$ s, the test passes. Record a Pass or Fail in the performance test record.

- d Select Stop to end the acquisition.



---

## To Test the Multi-Card Module

The multi-card test is only required for configured multi-card modules. Performing the test verifies the performance of the following specifications:

- Minimum master to master clock time
- Maximum state acquisition speed
- Setup/Hold time

Multi-card modules that were changed to one-card modules for the previous performance tests need to be reconfigured as a multi-card module for this test.

This test checks a combination of data channels using a single-edge clock at one selected setup/hold time.

### Equipment Required

Equipment	Critical Specifications	Recommended HP/ Agilent Model/Part
Pulse Generator	200 Mhz, 2.5 ns pulse width, < 600 ps rise time	8133A option 003
Digitizing Oscilloscope	≥ 6 GHz bandwidth, < 58 ps rise time	54750A w/ 54751A
Adapter	SMA(m)-BNC(f)	1250-1200
SMA Coax Cable (Qty 3)		8120-4948
Coupler (Qty 3)	BNC (m-m)	1250-0216
BNC Test Connector, 6x2 (Qty 3)		

---

## Set up the equipment

If you have not already done so, do the procedure “To Set up the Test Equipment and the Analyzer” on page 38. Ensure that the pulse generator and oscilloscope are set up according to the tables in that section.

---

## Set up the logic analyzer

- 1** Set up the Sampling tab.
  - a** In the Analyzer setup window, select the Sampling tab.
  - b** Select State Mode.
- 2** Assign pods 1 and 2 of the master card and all expander cards to Analyzer 1.
  - a** In the Analyzer setup window, select the Format tab.
  - b** Under the Format tab, select Pod Assignment.
  - c** In the pod Assignment window, use the mouse to drag the pods 1 and 2 to the Analyzer 1 column. Use the mouse to drag all pods 3 and 4 to the Unassigned Pods column.

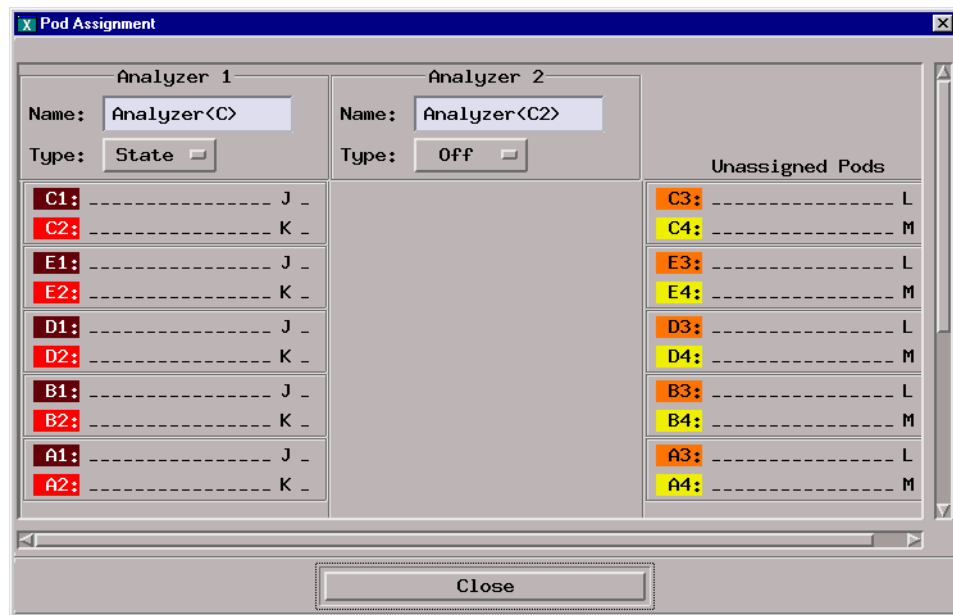

- d** Select Close to close the pod assignment window.

- 3** Set up the Format tab.
  - a** Under one of the pod fields, select TTL.
  - b** In the Pod Threshold window, ensure the Apply threshold settings to all pods checkbox is checked.
  - c** In the Pod Threshold window, select the Standard threshold voltage field. At the pop-up menu select ECL (-1.30 V).

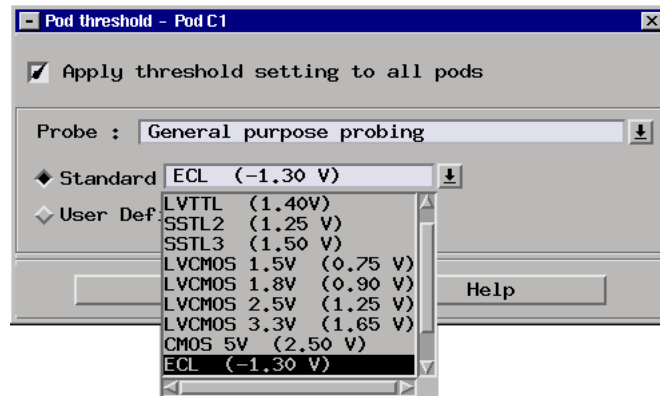

- d** Select Close to close the Pod Threshold window.

- 4 Set up the Trigger tab.
  - a In the Analyzer setup window, select the Trigger tab. Under the Trigger tab, select the Settings tab.
  - b Select the Acquisition Depth field, then select “8K”.
  - c Select the Trigger Position field, then select Start.

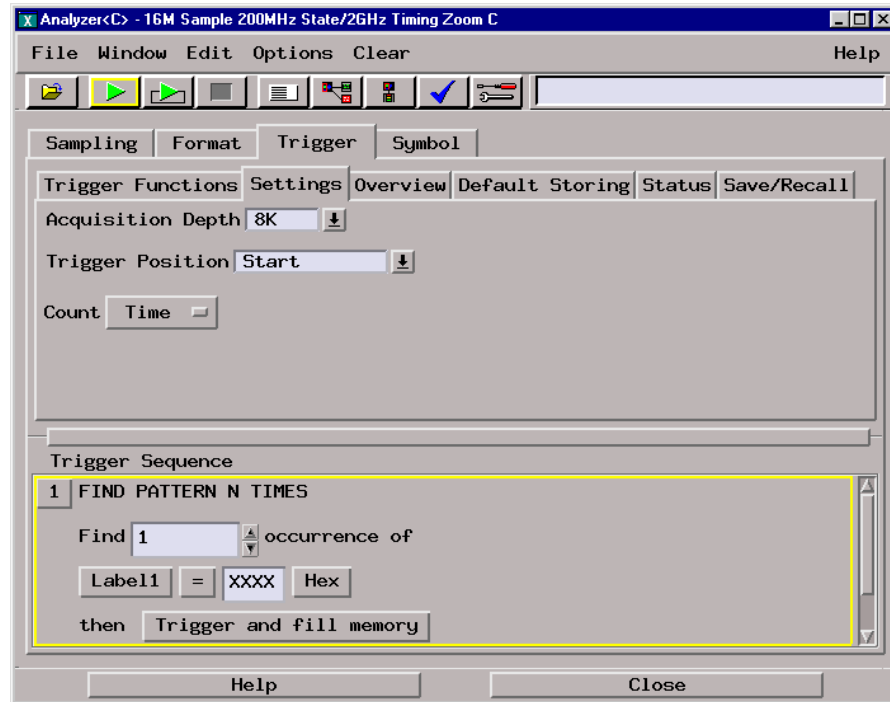

- 5 Set up the Listing window.
  - a In the Listing window, select the Markers tab.
  - b Select the G1: field and the Markers Setup window appears.
  - c Select the Time field associated with G1, and select Pattern. Select the Time field associated with G2, and select Pattern.



Note: Leave the Marker Setup window open. You will be entering numeric values in the “occurs” field after acquiring the test data.

## Connect the logic analyzer

- 1 Using the 6-by-2 test connectors, connect the logic analyzer clock and data channels listed in the following tables to the pulse generator.
- 2 Using SMA cables, connect channel 1, channel 2, and trigger from the oscilloscope to the pulse generator according to the following illustration.

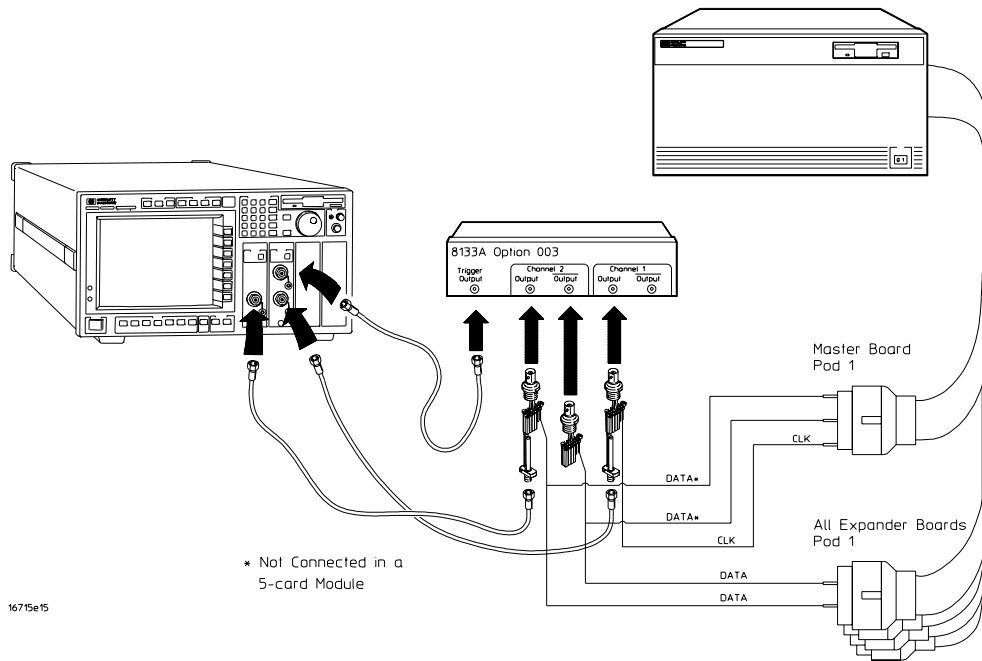

### Connect the Logic Analyzer to the Pulse Generator (2-, 3-, and 4-card module)

	Connect to 8133A Channel 2 Output	Connect to 8133A Channel 2 Output	Connect to 8133A Channel 1 Output
Master Board	Pod 1, channel 3	Pod 1, channel 11	J-clock
All Expander Boards	Pod 1, channel 3	Pod 1, channel 11	

### Connect the Logic Analyzer to the Pulse Generator (5-card module)

	Connect to 8133A Channel 1 Output	Connect to 8133A Channel 1 Output	Connect to 8133A Channel 1 Output
Master Board			J-clock
All Expander Boards	Pod 1, channel 3	Pod 1, channel 11	

For a 5-card module, do not connect the master board to the channel 1 output and output. Connect only the four expander boards.

- 3** Activate the data channels that are connected according to the previous table.
  - a** In the Analyzer setup window, select the Format tab.
  - b** Under the Format tab, select the field showing the channel assignments for Pod 1 of one of the Expander cards, then select Individual. Using the mouse, select channels 3 and 11. An asterisk means that a channel is turned on. Follow this step for the Pod 1 of each of the remaining Expander cards and for the Master card (if a 5-card module is not being tested).

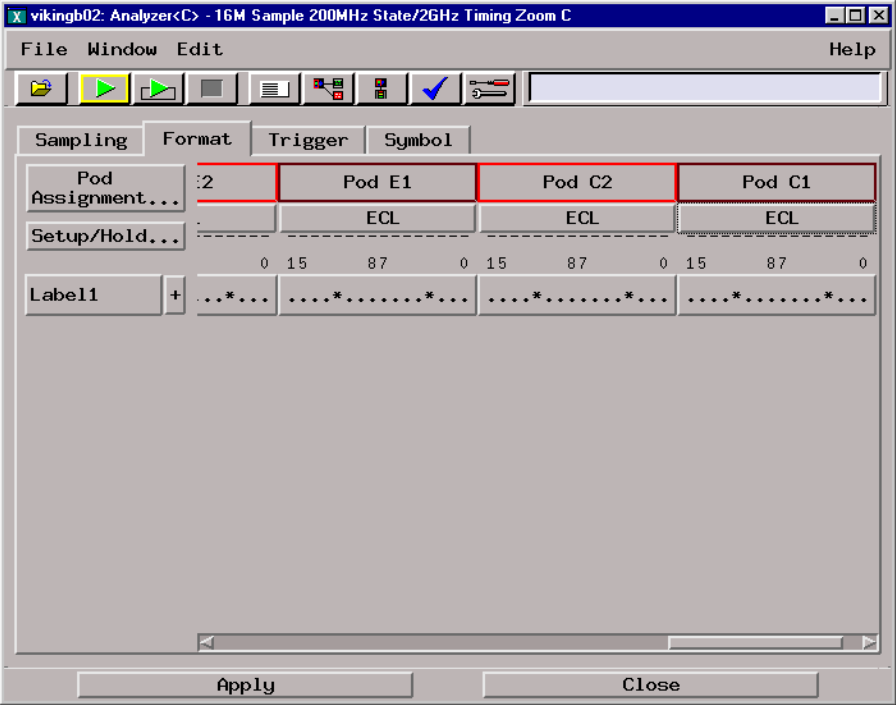

4 Configure the trigger pattern

- a Select the Trigger tab. Under the Trigger tab, select the Trigger Functions tab.
- b In the General State field, select Store nothing until pattern occurs. Then select Replace.
- c Under Trigger Sequence, locate the Label 1 = trigger pattern field. Enter the pattern according to the following table.

2-card module: "A"

3-card module: "2A"

4-card module: "AA"

5-card module: "AA"

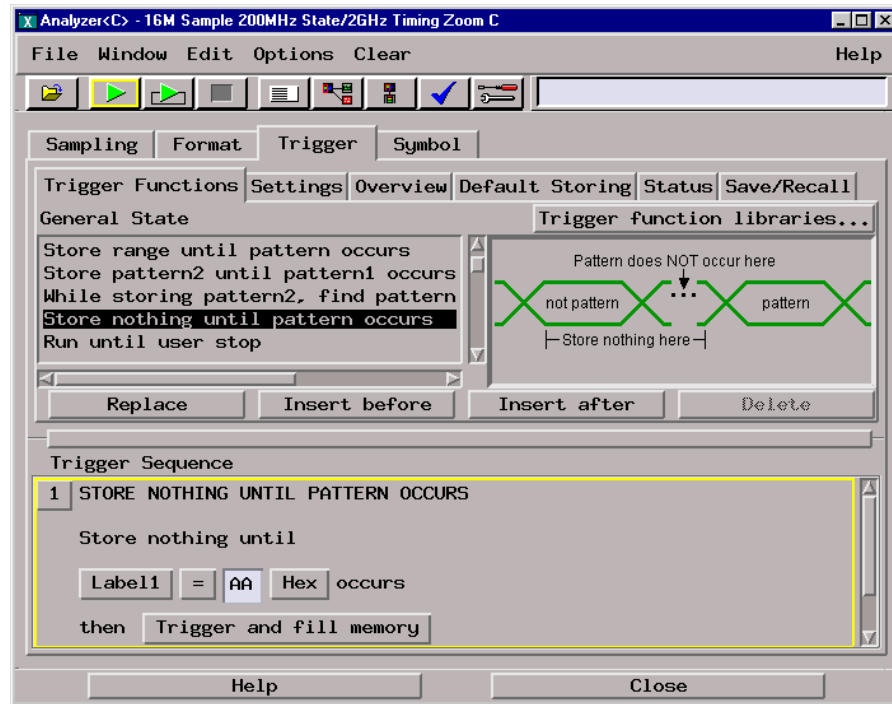



## Verify the test signal

- 1** Check the clock period. Using the oscilloscope, verify that the master-to-master clock time is 5.000 ns, +0 ps or -100 ps.
  - a** Turn on the pulse generator channel 1, channel 2, and trigger outputs.
  - b** In the oscilloscope Timebase menu, select Position. Using the oscilloscope knob, position the clock waveform so that a rising edge appears at the left of the display.
  - c** On the oscilloscope, select [Shift] Period: channel 2, then select [Enter] to display the clock period (Period(2)). If the period is more than 5.000 ns, go to step d. If the period is less than or equal to 5.000 ns but greater than 4.900 ns, go to step 2.
  - d** In the oscilloscope Timebase menu, increase Position 5.000 ns. If the period is more than 5.000 ns, decrease the pulse generator Period in 10 ps increments until one of the two periods measured is less than or equal to 5.000 ns but greater than 4.900 ns.

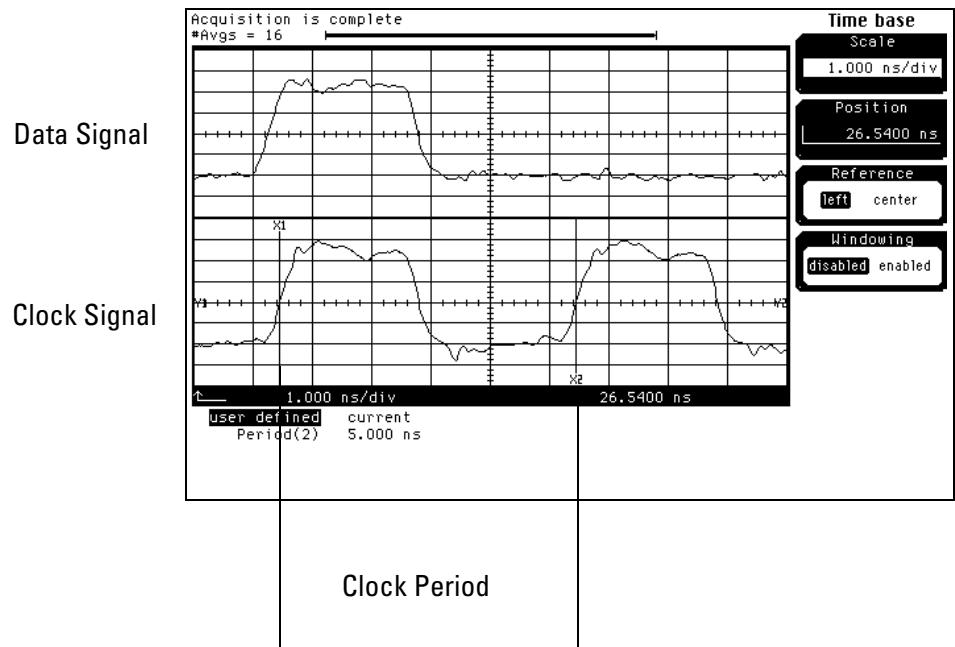

- 2 Check the data pulse width. Using the oscilloscope, verify that the data pulse width is 2.500 ns, +0 ps or -50 ps.
  - a In the oscilloscope Timebase menu, select Position. Using the oscilloscope knob, position the data waveform so that the waveform is centered on the screen.
  - b On the oscilloscope, select [Shift] + width: channel 1, then select [Enter] to display the data signal pulse width (+ width(1)).
  - c If the pulse width is outside the limits, adjust the pulse generator channel 2 width until the pulse width is within limits.

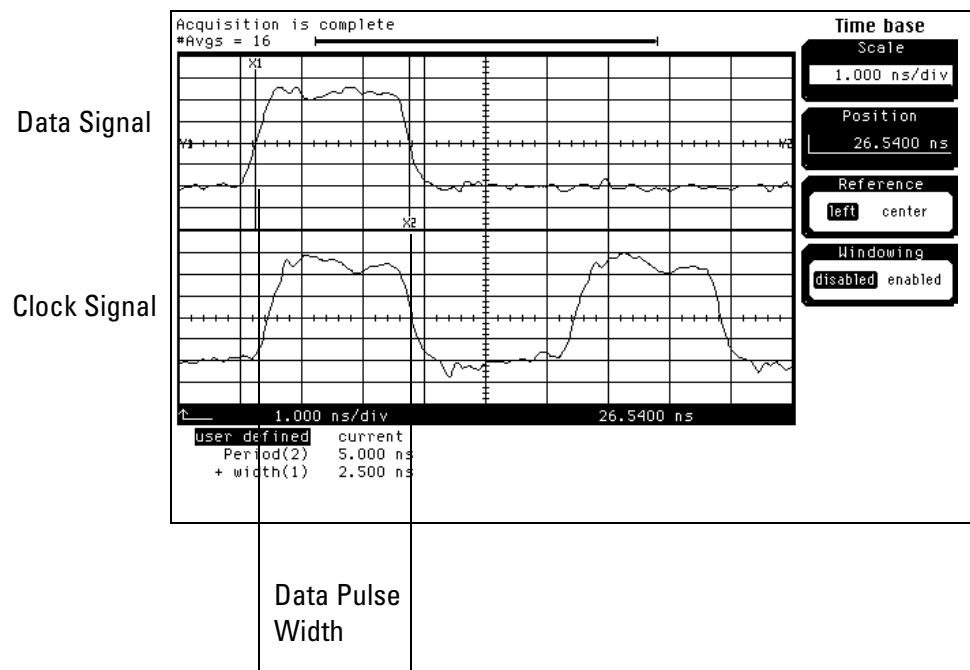

---

## Check the setup/hold combination

- 1 Select the logic analyzer setup/hold time.
  - a In the Analyzer setup window, select the Format tab.
  - b Under the Format tab, select Setup/Hold.
  - c In the Setup and Hold window, ensure All bits is selected.
  - d Enter 4.500 ns in the Setup: field.

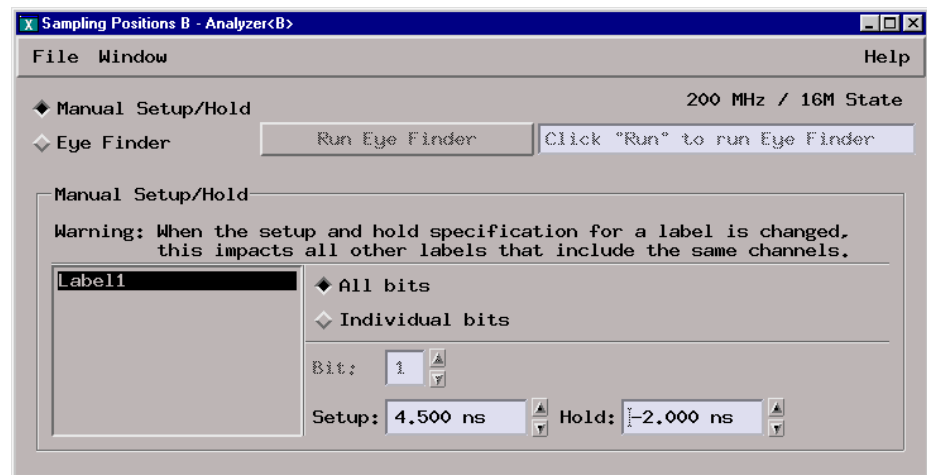

- e Select the close (X) button in the upper-right corner to close the Setup/ Hold window.
- 2 Disable the pulse generator channel 1 COMP (LED off).

- 3 Using the Delay mode of the pulse generator channel 1, position the pulses according to the setup/hold combination selected, +0.0 ps or -50 ps.
  - a On the Oscilloscope, select [Define meas] Define  $\Delta$ Time - Stop edge: rising.
  - b In the oscilloscope timebase menu, select Position. Using the oscilloscope knob, position both a clock and a data waveform on the display, with the rising edge of the clock waveform centered on the display.
  - c On the oscilloscope, select [Shift]  $\Delta$  Time, then select [Enter] to display the setup time ( $\Delta$ Time(1)-(2)).
  - d Adjust the pulse generator channel 1 Delay until the pulses are aligned for a setup time of 4.500 ns, +0.0 ps or -50 ps.

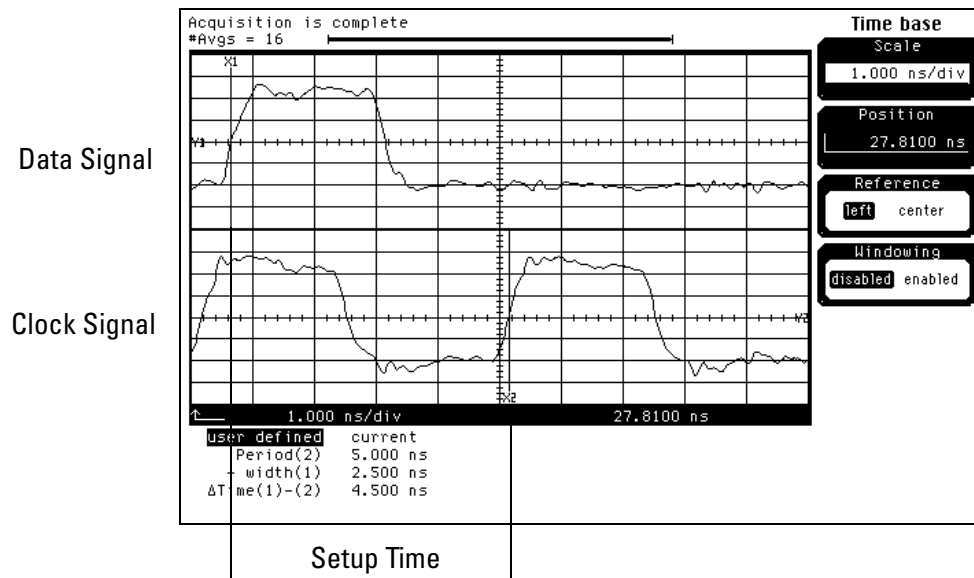

- 4 Select the clock to be tested.
  - a In the Analyzer setup window select the Sampling tab.
  - b Under the Sampling tab, select the clock edge field under the clock to be tested. Then select Rising Edge.

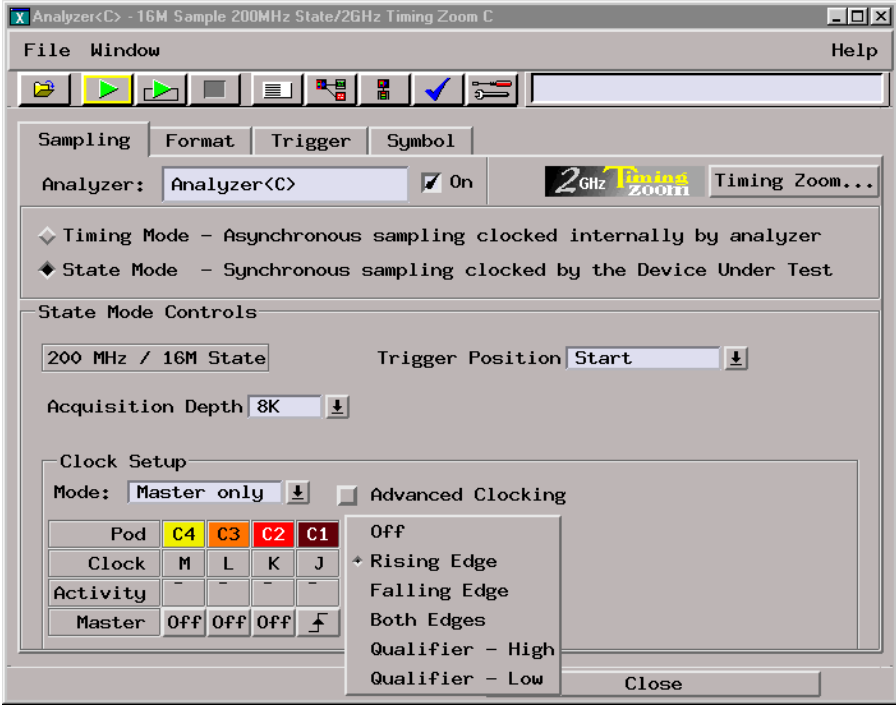

**Clocks**

J↑	K↑	L↑	M↑
----	----	----	----

- c Connect the clock input channel to be tested to the pulse generator channel 1 OUTPUT. Disconnect all other clock input channels.

5 Verify the test data.

a In the Listing window, select Run. The display should show an alternating pattern of

“A” and “5” (2-card module)

“2A” and “15” (3-card module)

“AA” and “55” (4- or 5-card module).

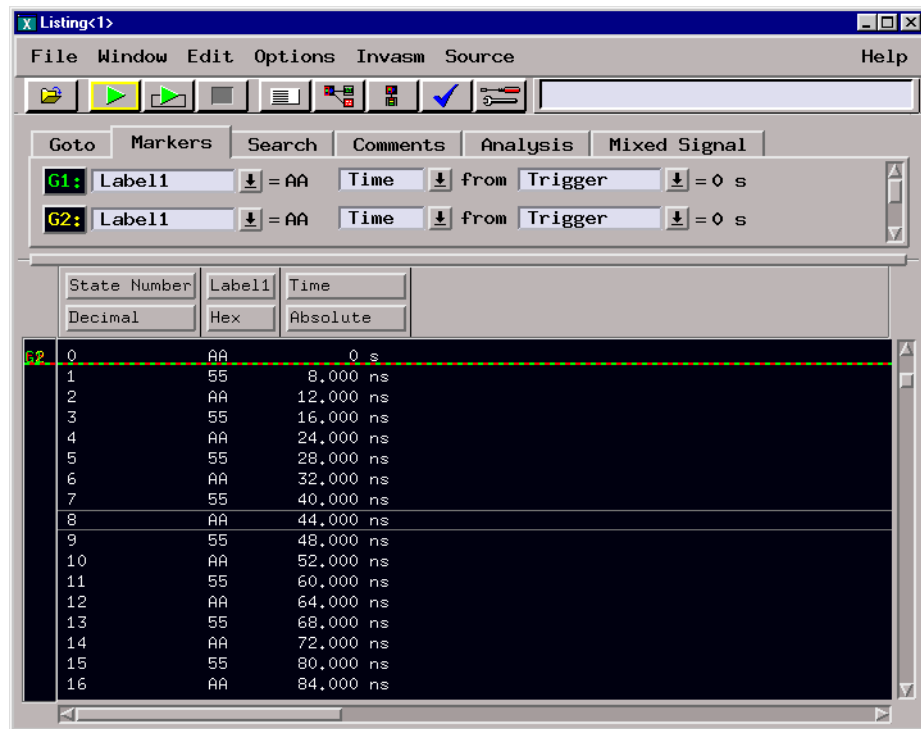

- b** In the Marker Setup window, select the Define... field associated with G1, and the G1 Marker Pattern window appears. In the pattern field, enter

“A” (2-card module)

“2A” (3-card module) or

“AA” (4- or 5-card module).

Select Apply, then select Close.



If the label selection field reads Label1\_TZ, you must select Label1 for the search term. To do this, select Label1\_TZ; then, in the popup menu, select Replace label. In the Replace popup menu, select Label1, then Apply, then Close.

- c** In the Marker Setup window, select the Define... field associated with G2, and the G2 Marker Pattern window appears. In the pattern field, enter

“5” (2-card module)

“15” (3-card module) or

“55” (4- or 5-card module).

Select Apply, then select Close.

If the Label selection field reads Label1\_TZ, you must select Label1 for the search term. Follow the same procedure as in b above.

- d** In the Marker Setup window, select the ‘occurs’ value field that corresponds to marker G1. Enter 4095.

- e In the Marker Setup window, select the 'occurs' value field that corresponds to marker G2. Enter 4096.

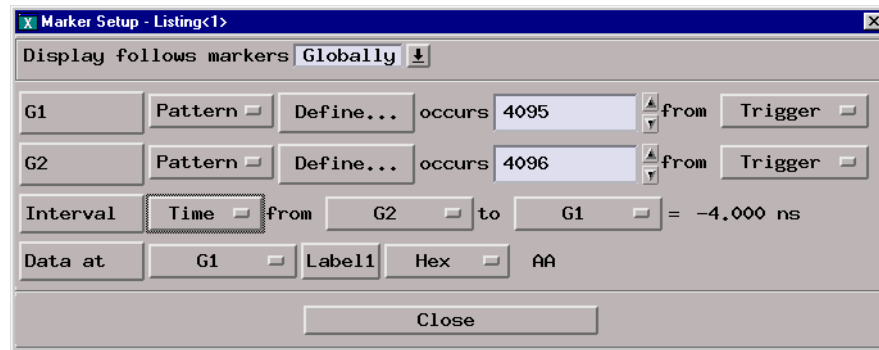

- f Select Close to apply the marker values to the data. If the “Pattern NOT found for marker...” error message does not appear, then the test passes. Record the Pass or Fail in the performance test record.
- 6 Repeat steps 4 and 5 for the next clock edge listed in the table in step 4, until all listed clock edges have been tested.



# Performance Test Record

**Performance Test Record**

<b>16740/41/42A Logic Analyzer</b>	
Serial No. _____	Work Order No. _____
Recommended Test Interval - 2 Year/4000 hours	Date _____
Recommended next testing _____	Temperature _____

Test	Settings	Results
<b>Self-Tests</b>		Pass/Fail _____
<b>Threshold Accuracy</b>	±(65 mV + 1.5% of threshold setting)	
Pod 1		Limits                      Measured
	ECL, ±84mV              ECL VL	-1.384 V                      _____
		ECL VH                      -1.216 V                      _____
	0 V, ±65 mV              0 V User VL	-65 mV                      _____
		0 V User VH                      +65 mV                      _____
Pod 2		
	ECL, ±84 mV              ECL VL	-1.384 V                      _____
		ECL VH                      -1.216 V                      _____
	0 V, ±65 mV              0 V User VL	-65 mV                      _____
		0 V User VH                      +65 mV                      _____
Pod 3		
	ECL, ±84 mV              ECL VL	-1.384 V                      _____
		ECL VH                      -1.216 V                      _____
	0 V, ±65 mV              0 V User VL	-65 mV                      _____
		0 V User VH                      +65 mV                      _____
Pod 4		
	ECL, ±84 mV              ECL VL	-1.384 V                      _____
		ECL VH                      -1.216 V                      _____
	0 V, ±65 mV              0 V User VL	-65 mV                      _____
		0 V User VH                      +65 mV                      _____

**Performance Test Record**

Test	Settings	Results	
<b>Single-Clock, Single-Edge Acquisition</b>			
All Pods	Setup/Hold Time 4.5/-2.0 ns	J↑	Pass/Fail
		K↑	_____
		L↑	_____
		M↑	_____
		J↓	_____
		K↓	_____
		L↓	_____
		M↓	_____
	Setup/Hold Time -2.0/4.5 ns	J↑	_____
		K↑	_____
		L↑	_____
		M↑	_____
		J↓	_____
		K↓	_____
		L↓	_____
		M↓	_____

Test	Settings	Results
<b>Multiple-clock, Multiple-edge acquisition</b>		
All Pods	Setup/Hold Time 5.0/2.0 ns	Pass/Fail _____ Pass/Fail _____ J↑ + K↑ + L↑ + M↑ _____ J↓ + K↓ + L↓ + M↓ _____
	Setup/Hold Time -1.5/4.5 ns	J↑ + K↑ + L↑ + M↑ _____ J↓ + K↓ + L↓ + M↓ _____
<b>Single-Clock, Multiple-Edge Acquisition</b>		
All Pods	Setup/Hold Time 5.0/2.0 ns	Pass/Fail _____ J↓ _____ K↓ _____ L↓ _____ M↓ _____
	Setup/Hold Time -1.5/4.5 ns	J↓ _____ K↓ _____ L↓ _____ M↓ _____
<b>Time Interval Accuracy</b>		
	Interval time from G1 to G2 749.921 - 750.079 μs	Pass/Fail _____
<b>Multi-Card Test</b>		
	Setup/Hold Time 4.5/-2.0 ns	Pass/Fail _____ J↑ _____ K↑ _____ L↑ _____ M↑ _____

**Performance Test Record**

---

## Calibrating

This chapter gives you instructions for calibrating the logic analyzer.

## **Calibration Strategy**

The 16740/41/42A logic analyzer does not require an operational accuracy calibration. To test the module against the module specifications, refer to "Testing Performance" in chapter 3.

---

## Troubleshooting

This chapter helps you troubleshoot the module to find defective assemblies.

The troubleshooting consists of flowcharts, self-test instructions, a cable test, and a test for the auxiliary power supplied by the probe cable.

If you suspect a problem, start at the top of the first flowchart. During the troubleshooting instructions, the flowcharts will direct you to perform the self-tests or the cable test.

The service strategy for this instrument is the replacement of defective assemblies. This module can be returned to Agilent Technologies for all service work, including troubleshooting. Contact your nearest Agilent Technologies Sales Office for more details.

---

**CAUTION:**

---

Electrostatic discharge can damage electronic components. Use grounded wrist-straps and mats when you perform any service to this instrument or to the cards in it.

---

## To use the flowcharts

Flowcharts are the primary tool used to isolate defective assemblies. The flowcharts refer to other tests to help isolate the trouble. The circled numbers on the charts indicate connections with the other flowcharts. Start your troubleshooting at the top of the first flowchart.

## Mainframe Operating System

Before starting the troubleshooting on an 16740/41/42A, ensure that the required version of Agilent Technologies 16700A-series mainframe operating system is installed on the mainframe. The required operating system software versions are listed in “Mainframe and Operating System” on page 10. To check the operating system version number, open the System Administration window, click the Admin tab, then click About...

If the proper version is not loaded, obtain a copy of the updated operating system software and install it in the logic analyzer.



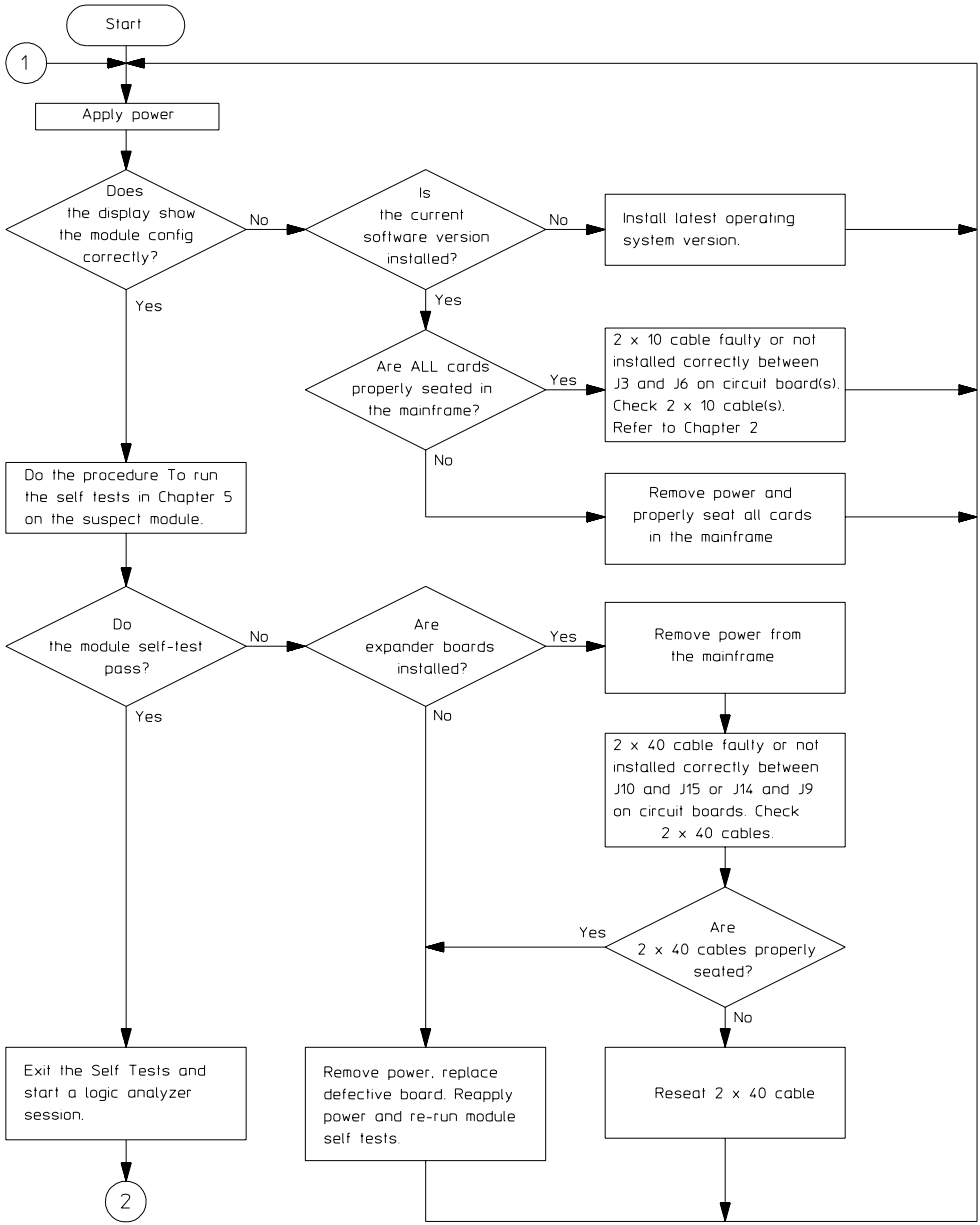

16750h01

Troubleshooting Flowchart 1

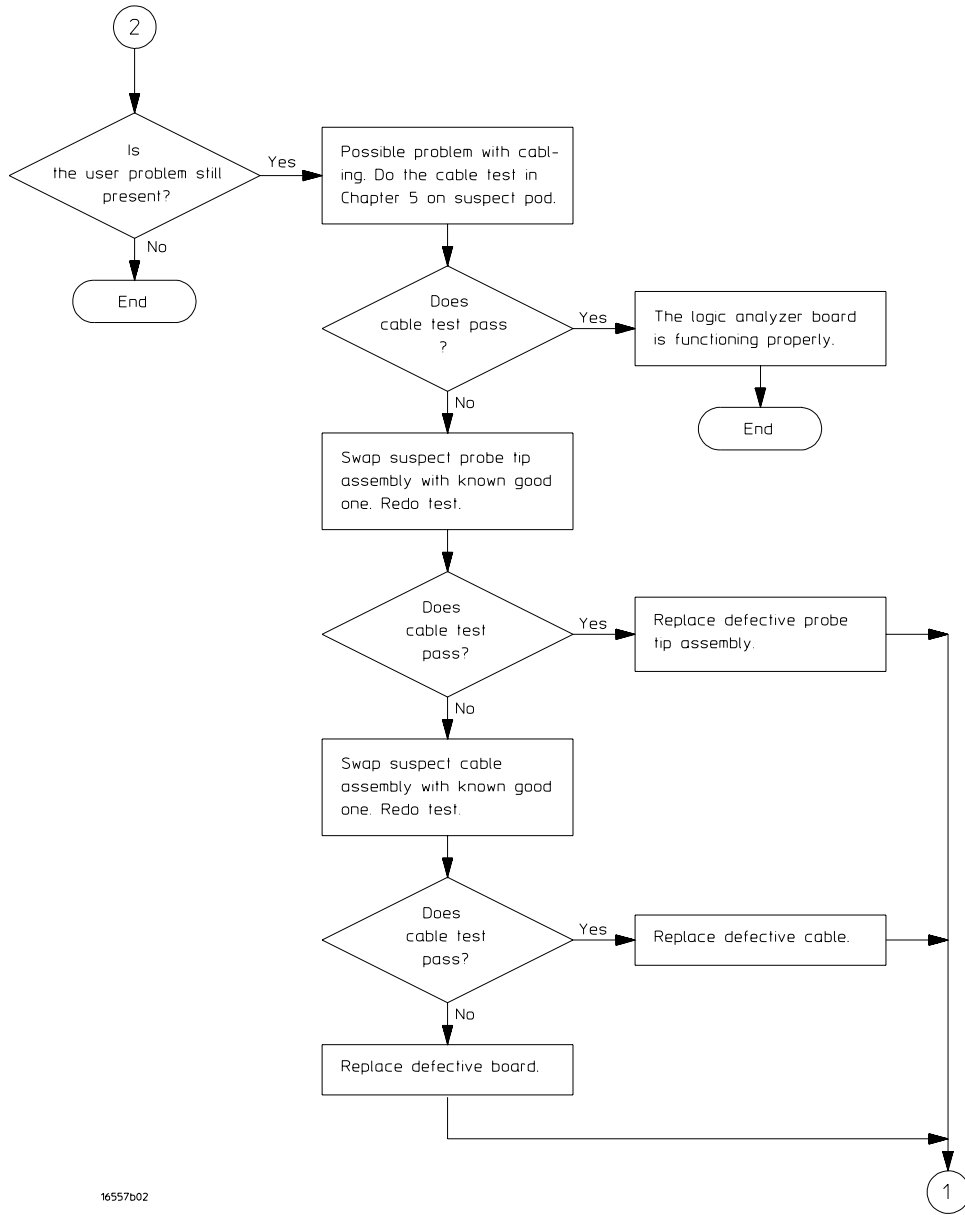

16557b02

Troubleshooting Flowchart 2

---

## To run the self-tests

Self-tests identify the correct operation of major, functional subsystems of the module. You can run all self-tests without accessing the module. If a self-test fails, the troubleshooting flowcharts instruct you to change a part of the module.

To run the self-tests:

- 1** In the System window, select System Admin.
- 2** In the System Administration window, select the Admin tab, then select Self-Test. At the Test Query window, select Yes.

The tests can be run individually, or all the tests can be run by selecting Test All at the bottom of the Self Test window. Note that if Test All is selected, system tests requiring user action will not be run. For more information, refer to Chapter 8 in the mainframe service manual.

- 3** In the Self Test window under the System tab, select System CPU Board.
- 4** Run the floppy drive test.
  - a** In the Self Test: System CPU Board window, select Floppy Drive Test.
  - b** Insert a DOS-formatted disk with 300KB of available space in the mainframe floppy drive.
  - c** In the Test Query window, select OK.

The Test Query window instructs you to insert the disk into the disk drive. The other System CPU Board tests require similar user action to successfully run the test.

- 5** In the Self Test: System CPU Board window, select Close to close the window.
- 6** In the Self Test window, select PCI Board. Select Test All to run all PCI board tests.
- 7** In the Self Test window, select the Master Frame tab. Select the 16740/41/42A module to be tested, then select Test All to run all the module tests. The module test status should indicate PASSED (see screen on next page).

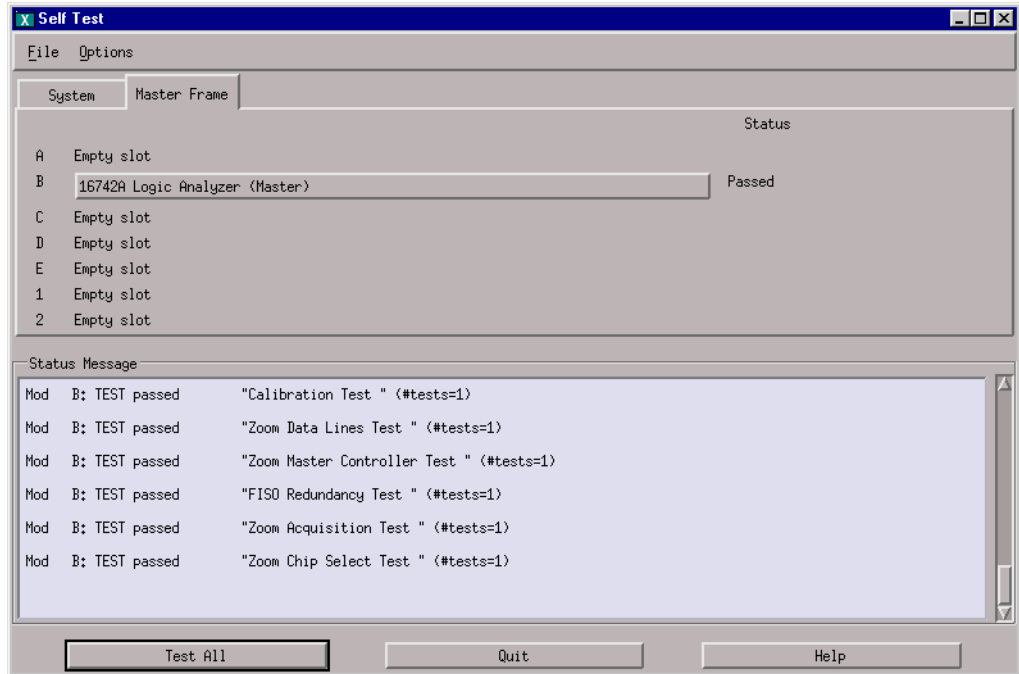

Refer to Chapter 8 in the mainframe service manual for more information on system tests that are not executed.

---

## To exit the test system

To exit the test system

- 1** Select Close to close any module or system test windows.
- 2** In the Self Test window, select Quit.
- 3** In the session manager window, select Start Session to launch a new logic analyzer session.

---

## To test the cables

This test allows you to functionally verify the probe cable and probe tip assembly of any of the logic analyzer pods. Only one probe cable can be tested at a time. Repeat this test for each probe cable to be tested.

### Equipment Required

Equipment	Critical Specification	Recommended HP/ Agilent Model/Part
Pulse Generator	100 MHz, 3.5 ns pulse width, < 600 ps rise time	8133A Option 003
6x2 Test Connectors (Qty 4)		

- 1 If you have not already done so, do the procedure "To Set up the Test Equipment and the Analyzer" on page 38 in Chapter 3.
- 2 Set up the pulse generator.
  - a Set up the pulse generator according to the following table

### Pulse Generator Setup

Timebase	Channel 2	Channel 1	Trigger
Mode: Int	Mode: Square	Mode: Square	Divide: Divide ÷ 1
Period: 25.000 ns	Delay: 0.000 ns	Delay: 0.000 ns	Ampl: 0.50 V
	High: 3.00 V	High: 3.00 V	Offs: 0.00 V
	Low: 0.00 V	Low: 0.00 V	
	COMP: Disabled (LED Off)	COMP: Disabled (LED Off)	

- b Enable the pulse generator channel 1 and channel 2 outputs (LED off).

- 3** Set up the Sampling tab.
  - a** In the Analyzer setup window, select the Sampling tab.
  - b** Select State Mode.
  - c** Select Master Clock. In the Master Clock window, select both edges for the J clock (J $\updownarrow$ ). Turn off the other clocks.
  - d** Select Acquisition Depth field, then select 8K.

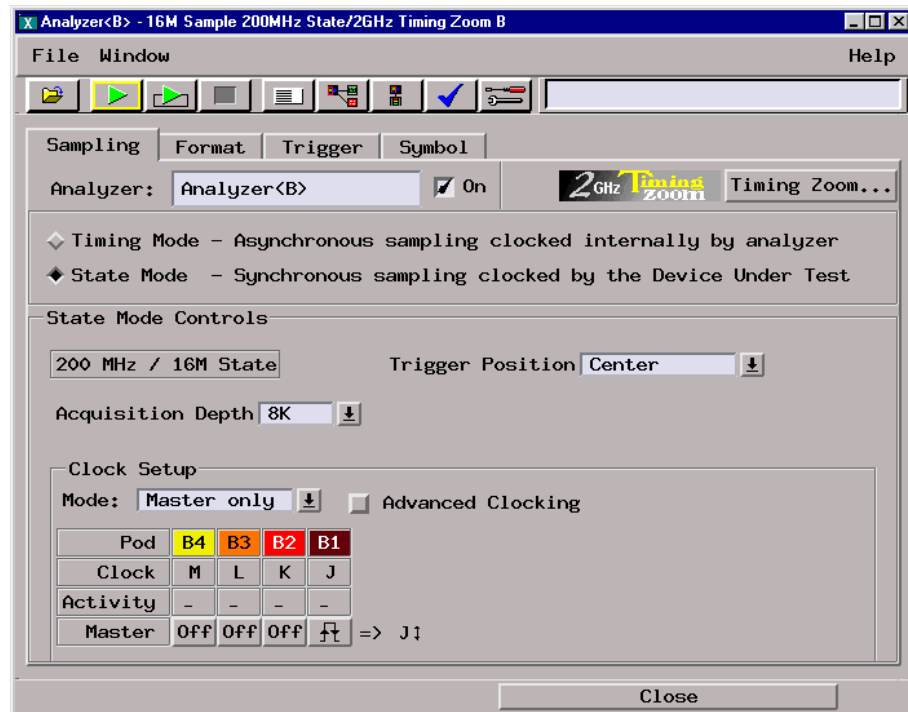

- 4 Assign all pods to Analyzer 1, and configure the pod under test.
  - a Select the Format tab. Under the Format tab, select Pod Assignment.
  - b Use the mouse to drag the pods to the Analyzer 1 column.

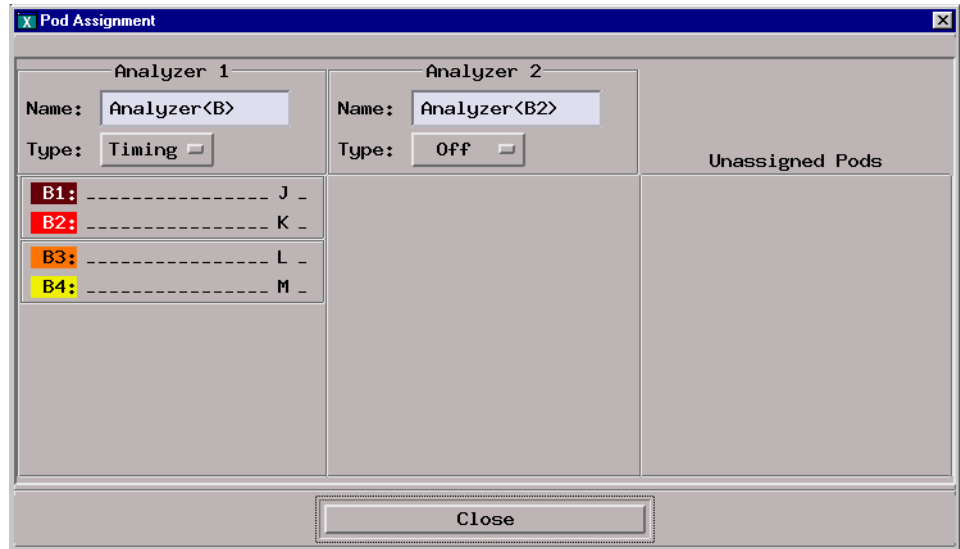

- c Select the field showing the channel assignments for the pod under test. In the pop-up menu, select the asterisk field to put asterisks in the channel positions, activating the channels. Select Done.
- d Select Setup/Hold, then enter 3.000 ns in the Setup: field. Select OK to close the Setup/Hold window.
- e Ensure the threshold is set to TTL. If not, select the threshold field, then select TTL

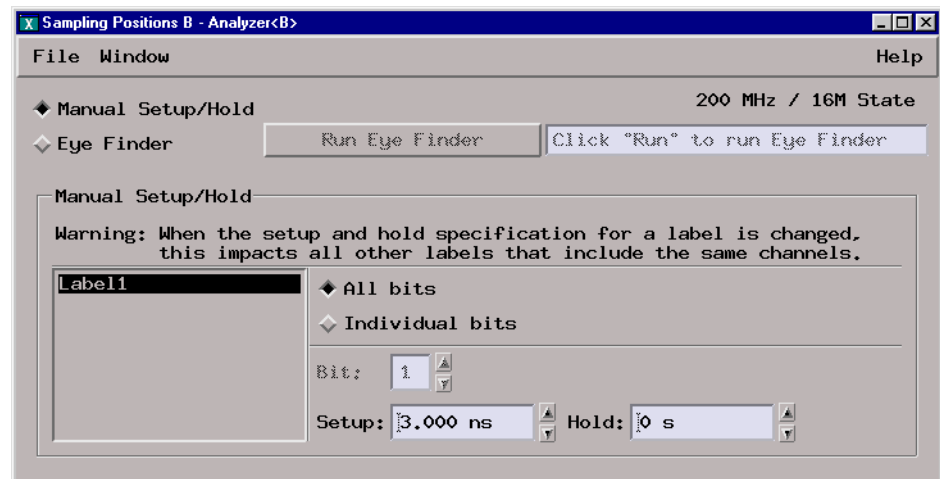

- 5 Set up the Listing window.
  - a In the Analyzer Setup window, select Window, then select Slot n: Analyzer (where “n” is the slot the module under test is installed), then select Listing. A Listing window opens.
  - b Right click on the Hex field and change the Lab1 base to Binary.

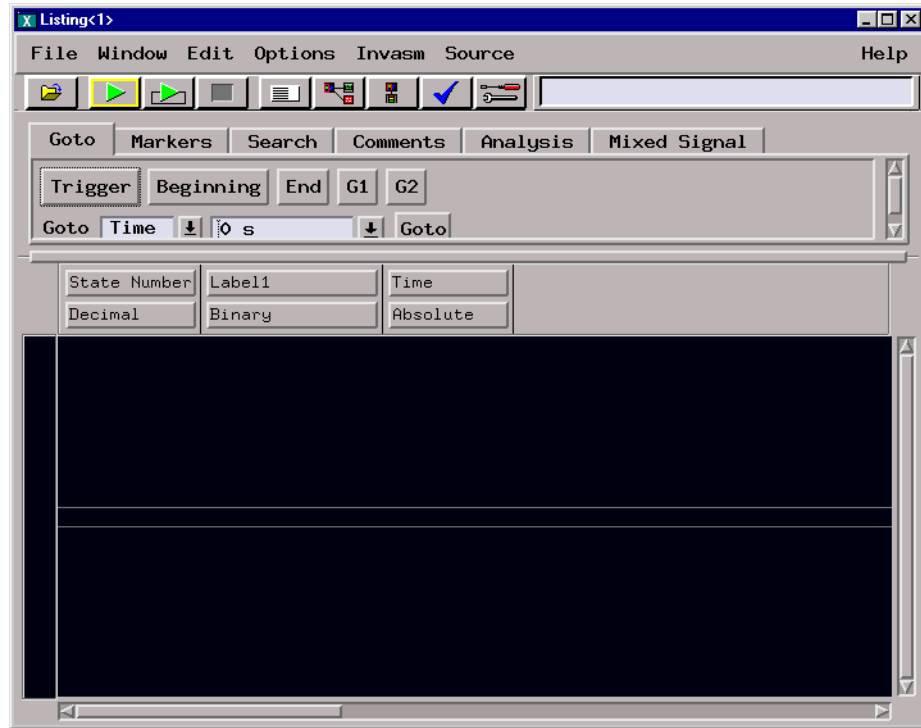

- 6 Using four 6-by-2 test connectors, connect the logic analyzer to the pulse generator channel outputs. To make the test connectors, see chapter 3, "Testing Performance."
  - a Connect the even-numbered channels of the lower byte of the pod under test to the pulse generator channel 1 Output.
  - b Connect the odd-numbered channels of the lower byte of the pod under test to the pulse generator channel 1 Output.
  - c Connect the even-numbered channels of the upper byte of the pod under test and the J clock channel to the pulse generator channel 2 Output. J clock is located on Pod 1.
  - d Connect the odd-numbered channels of the upper byte of the pod under test to the pulse generator channel 2 Output.



- 7 On the logic analyzer, select Run. The listing should look similar to the figure below. Ignore any error messages dealing with the G1 and G2 markers.

The screenshot shows a logic analyzer listing window titled 'Listing<1>'. The window has a menu bar (File, Window, Edit, Options, Invasm, Source, Help) and a toolbar with various icons. Below the toolbar are tabs for 'Goto', 'Markers', 'Search', 'Comments', 'Analysis', and 'Mixed Signal'. There are also buttons for 'Trigger', 'Beginning', 'End', 'G1', and 'G2'. A 'Goto' field is set to 'Time' with a dropdown arrow and a 'Goto' button. The main area is a table with columns for State Number, Label1, and Time. The table contains 17 rows of data, with the first row highlighted in green. A red dashed line is drawn across the table at the 0 ns mark.

State Number	Label1	Time
Decimal	Binary	Absolute
0	0101010101010101	0 s
1	1010101010101010	4,000 ns
2	0101010101010101	8,000 ns
3	1010101010101010	16,000 ns
4	0101010101010101	20,000 ns
5	1010101010101010	24,000 ns
6	0101010101010101	28,000 ns
7	1010101010101010	36,000 ns
8	0101010101010101	40,000 ns
9	1010101010101010	44,000 ns
10	0101010101010101	48,000 ns
11	1010101010101010	56,000 ns
12	0101010101010101	60,000 ns
13	1010101010101010	64,000 ns
14	0101010101010101	72,000 ns
15	1010101010101010	76,000 ns
16	0101010101010101	80,000 ns

- 8 If the listing looks like the figure, then the cable passed the test.

If the listing does not look similar to the figure, then there is a possible problem with the cable or probe tip assembly. Causes for cable test failures include:

- open channel.
- channel shorted to a neighboring channel.
- channel shorted to either ground or a supply voltage.

Return to the troubleshooting flowchart.

---

## To test the auxiliary power

The +5 V auxiliary power is protected by a current overload protection circuit. If the current on pins 1 and 39 exceeds 0.33 amps, the circuit will open. When the short is removed, the circuit will reset in approximately 1 minute. There should be +5 V after the 1 minute reset time.

---

### Equipment Required

---

Equipment	Critical Specifications	Recommended HP/ Agilent Model/Part
Digital Multimeter	na	E2373A

- Using the multimeter, verify the +5 V on pins 1 and 39 of the probe cables.

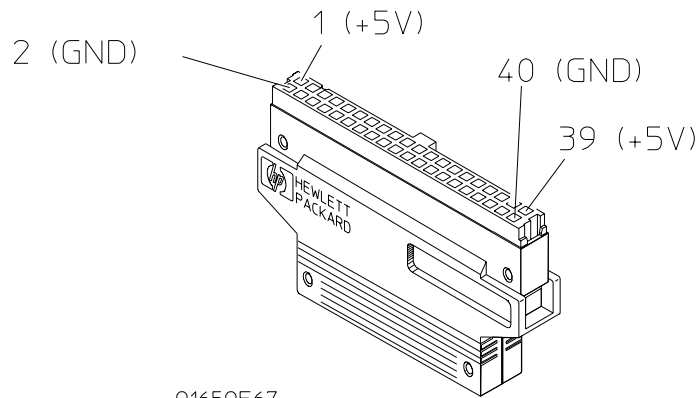

---

## Replacing Assemblies

This chapter contains the instructions for removing and replacing the logic analyzer module, the circuit board of the module, and the probe cables of the module as well as the instructions for returning assemblies.

---

**CAUTION:**

---

Turn off the instrument before installing, removing, or replacing a module in the instrument.

## Tools Required

- A T10 TORX screwdriver, to remove screws connecting the probe cables and screws connecting the back panel.

---

## To remove the module

---

**CAUTION:**

---

Electrostatic discharge can damage electronic components. Use grounded wriststraps and mats when performing any service to this module.

- 1 Remove power from the instrument.
  - a Exit all logic analysis sessions. In the session manager, select Shutdown.
  - b At the query, select Power Down.
  - c When the “OK to power down” message appears, turn the instrument off.
  - d Disconnect the power cord.
- 2 Loosen the thumb screws.

Starting from the top, loosen the thumb screws on the filler panels and cards located above the module and the thumb screws of the module.

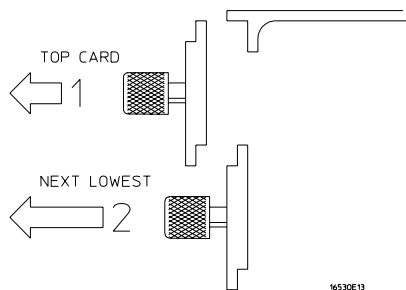

- 3 Starting from the top, pull the cards and filler panels located above the module half-way out.
- 4 If the module consists of a single card, pull the card completely out.  
If the module consists of multiple cards, pull all cards completely out.

**5** Push all other cards into the card cage, but not completely in.

This is to get them out of the way for removing and replacing the module.

**6** If the module consist of a single card, replace the faulty card.

If the module consists of multiple cards, remove the cables from J9 and J10 of all cards. Remove the 2x10 cables from J4, J5, J7, and J8 from the master card. Remove the faulty card from the module.

---

## To replace the circuit board

- 1** Remove the three screws connecting the probe cables to the back panel, then disconnect the probe cables.
- 2** Remove the four screws attaching the ground spring and back panel to the circuit board, then remove the back panel and the ground spring.
- 3** Replace the faulty circuit board with a new circuit board. On the faulty board, make sure the 20-pin ribbon cable is connected between J3 and J6.
- 4** Position the ground spring and back panel on the back edge of the replacement circuit board. Install four screws to connect the back panel and ground spring to the circuit board.
- 5** Connect the probe cables, then install three screws to connect the cables to the back panel.

---

**CAUTION:**

If you over tighten the screws, the threaded inserts on the back panel might break off of the back panel. Tighten the screws only enough to hold the cable in place.

---

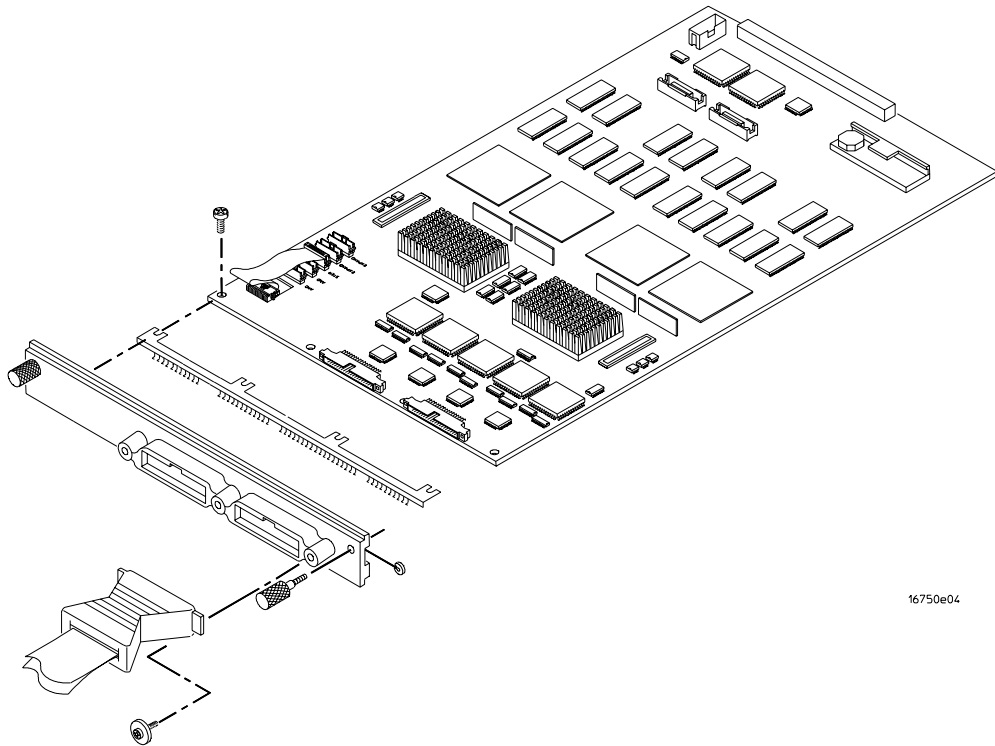

16750e04

---

## To replace the module

- 1 If the module consists of one card, go to step 2.

If the module consists of more than one card, connect the cables together in a master/expander configuration. Follow the procedure "To configure a multichannel module" in chapter 2.

- 2 Slide the cards above the slots for the module about halfway out of the mainframe.
- 3 With the probe cables facing away from the instrument, slide the module approximately halfway into the mainframe.

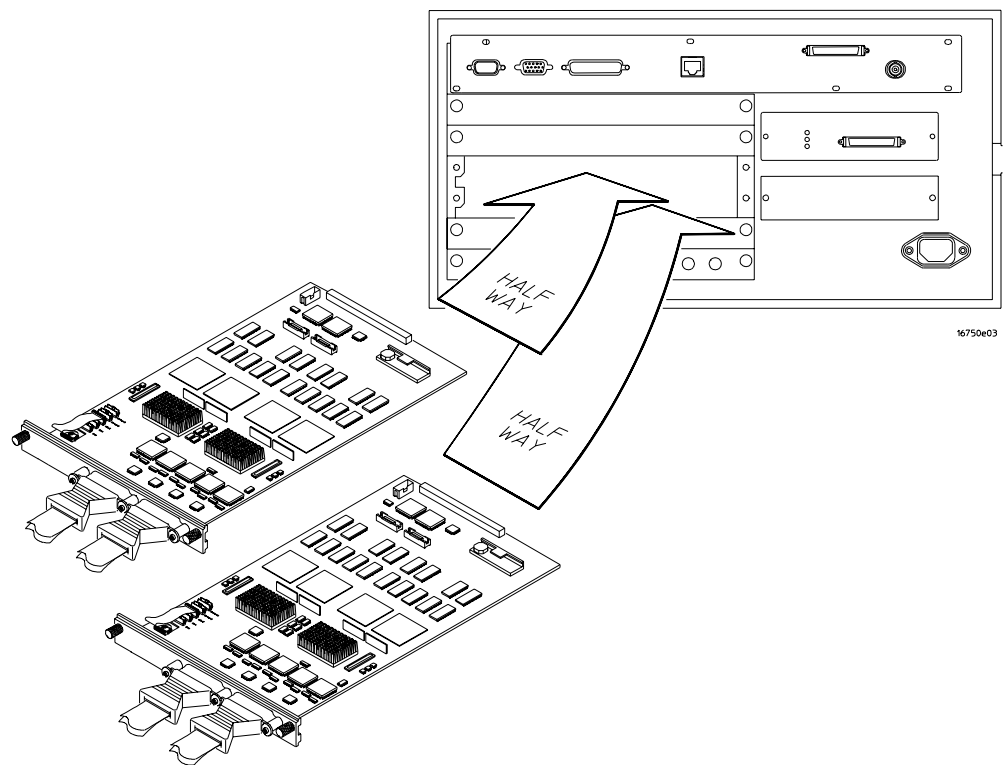

- 4 Slide the complete module into the mainframe, but not completely in.  
Each card in the instrument is firmly seated and tightened one at a time in step 6.

- 5** Position all cards and filler panels so that the endplates overlap.

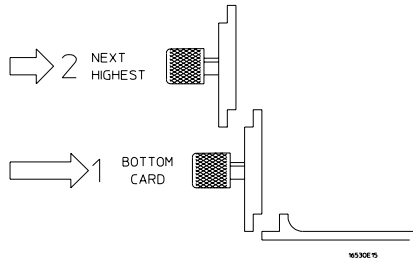

- 6** Seat the cards and tighten the thumbscrews.

Starting with the bottom card, firmly seat the cards into the backplane connector of the mainframe. Keep applying pressure to the center of the card endplate while tightening the thumbscrews finger-tight. Repeat this for all cards and filler panels starting at the bottom and moving to the top.

---

**CAUTION:**

---

Correct air circulation keeps the instrument from overheating. For correct air circulation, filler panels must be installed in all unused card slots. Keep any extra filler panels for future use.

---

### To replace the probe cable

- 1** Remove power from the instrument.
  - a** Exit all logic analysis sessions. In the session manager, select Shutdown.
  - b** At the query, select Power Down.
  - c** When the “OK to power down” message appears, turn the instrument off.
  - d** Disconnect the power cord.
- 2** Remove the screws that hold the probe cable to the rear panel of the module.
- 3** Remove the faulty probe cable from the connector and install the replacement cable.
- 4** Install the label on the new probe.

If you order a new probe cable, you will need to order new labels. Probe cables shipped with the module are labeled. Probe cables shipped separately are not labeled. Refer to chapter 7, "Replaceable Parts," for the part numbers and



ordering information.

- 5 Install the screws connecting the probe cable to the rear panel of the module.

---

**CAUTION:**

---

If you over tighten the screws, the threaded inserts on the back panel might break off of the back panel. Tighten the screws only enough to hold the cable in place.

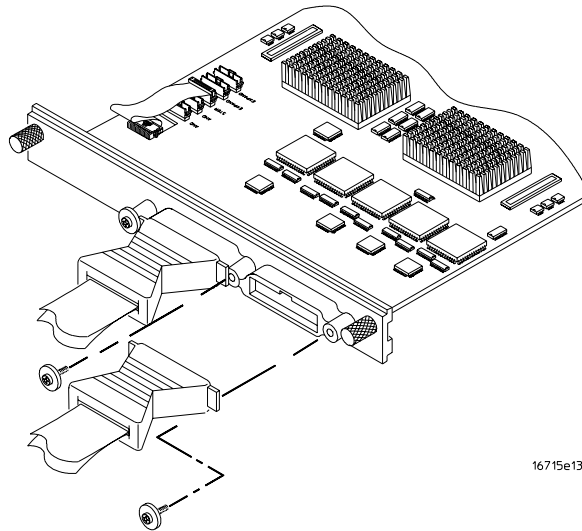

---

## To return assemblies

Before shipping the module to Agilent Technologies, contact your nearest Agilent Technologies Sales Office for additional details. In the U.S., call 1-800-403-0801.

- 1 Write the following information on a tag and attach it to the module.

- Name and address of owner
- Model number
- Serial number
- Description of service required or failure indications

- 2 Remove accessories from the module.

Only return accessories to Agilent Technologies if they are associated with the failure symptoms.

- 3 Package the module.

You can use either the original shipping containers, or order materials from an Agilent Technologies sales office.

---

**CAUTION:**

---

For protection against electrostatic discharge, package the module in electrostatic material.

- 4 Seal the shipping container securely, and mark it FRAGILE.

---

## Replaceable Parts

This chapter contains information for identifying and ordering replaceable parts for your module.

## Replaceable Parts Ordering

### **Parts listed**

To order a part on the list of replaceable parts, quote the Agilent Technologies part number, indicate the quantity desired, and address the order to the nearest Agilent Technologies Sales Office.

### **Parts not listed**

To order a part not on the list of replaceable parts, include the model number and serial number of the module, a description of the part (including its function), and the number of parts required. Address the order to your nearest Agilent Technologies Sales Office.

### **Direct mail order system**

To order using the direct mail order system, contact your nearest Agilent Technologies Sales Office.

Within the USA, Agilent Technologies can supply parts through a direct mail order system. The advantages to the system are direct ordering and shipment from the Agilent Technologies Part Center in Mountain View, California. There is no maximum or minimum on any mail order. (There is a minimum amount for parts ordered through a local Agilent Technologies Sales Office when the orders require billing and invoicing.) Transportation costs are prepaid (there is a small handling charge for each order) and no invoices.

In order for Agilent Technologies to provide these advantages, a check or money order must accompany each order. Mail order forms and specific ordering information are available through your local Agilent Technologies Sales Office. Addresses and telephone numbers are located in a separate document shipped with the *Agilent Technologies 16700-Series Logic Analysis System Service Manual*.

### **Exchange assemblies**

Some assemblies are part of an exchange program with Agilent Technologies.

The exchange program allows you to exchange a faulty assembly with one that has been repaired and performance verified by Agilent Technologies.

After you receive the exchange assembly, return the defective assembly to Agilent Technologies. A United States customer has 30 days to return the defective assembly. If you do not return the defective assembly within the 30 days, Agilent Technologies will charge you an additional amount. This amount is the difference in price between a new assembly and that of the exchange assembly. For orders not originating in the United States, contact your nearest

Agilent Technologies Sales Office for information.

**See Also**

"To return assemblies," page 146.

---

## Replaceable Parts List

The replaceable parts list is organized by reference designation and shows exchange assemblies, electrical assemblies, then other parts.

Information included for each part on the list consists of the following:

- Reference designator
- Agilent Technologies part number
- Total quantity included with the module (Qty)
- Description of the part

Reference designators used in the parts list are as follows:

- A Assembly
- H Hardware
- J Connector
- MP Mechanical Part
- W Cable

<b>Replaceable Parts</b>			
<b>Ref. Des.</b>	<b>Agilent Part Number</b>	<b>QTY</b>	<b>Description</b>
	16740-69504	1	Exchange Board Assembly (16740A)
	16741-69504	1	Exchange Board Assembly (16741A)
	16742-69504	1	Exchange Board Assembly (16742A)
A1	16740-66504	1	Board Assembly (16740A)
A1	16741-66504	1	Board Assembly (16741A)
A1	16742-66504	1	Board Assembly (16742A)
A2	16555-61605	1	Cable Assembly (2x10)
A3	16715-61601	2	Cable Assembly-Logic Analyzer
A4	01650-61608	4	Probe Tip Assembly
A6	16715-60001	1	Cable Kit-Master/Expander (2x40, Qty 2 cables)
A7	1252-8420	2	Probe Cable Socket - 50 pin
E1	5959-9333	1	Probe Leads Replace (5 Per Package)
E2	5959-9334	4	Probe Ground Replace (5 Per Package)
E3	5959-9335	0	Pod Ground Replace (2 Per Package)
E4	5090-4833	4	Grabber Kit Assembly (20 Grabbers Per Package)
H1	16500-22401	2	Panel Screw
H2	16715-29101	1	Ground Spring
H3	0510-0684	2	Retaining Ring
H4	0515-0430	4	MS M3.0X0.5X6MM PH T10 (Endplate Screw)
H5	0515-2306	3	Screw Sems M3 X 0.5X10mm (Cable Retaining Screw)
MP1	01650-94312	1	Label-Probe and Cable
MP2	16715-40501	1	Module Panel
MP3	16740-94301	1	Label-ID (16740A)
MP3	16741-94301	1	Label-ID (16741A)
MP3	16742-94301	1	Label-ID (16742A)
MP4	7121-0850	4	Label-Antistatic

## Exploded View

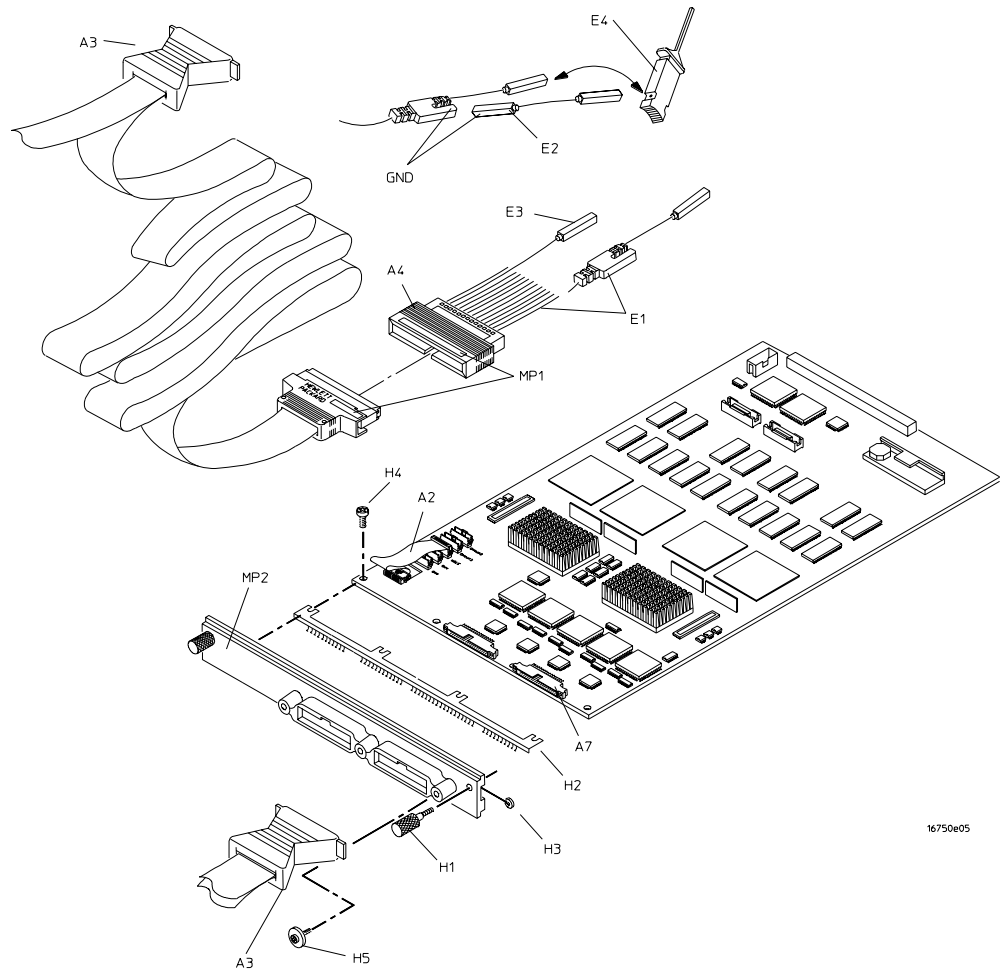

Exploded view of the 16740/41/42A logic analyzer





---

## Theory of Operation

This chapter presents the theory of operation for the logic analyzer module and describes the self-tests.

The information in this chapter is to help you understand how the module operates and what the self-tests are testing. This information is not intended for component-level repair.

## Block-Level Theory

The block-level theory of operation is divided into two parts: theory for the logic analyzer used as a single-card module or as a master card in a multi-card module, and theory for the logic analyzer used as an expander card in a multi-card module. A block diagram is shown before each theory.

### The 16740/41/42A logic analyzer

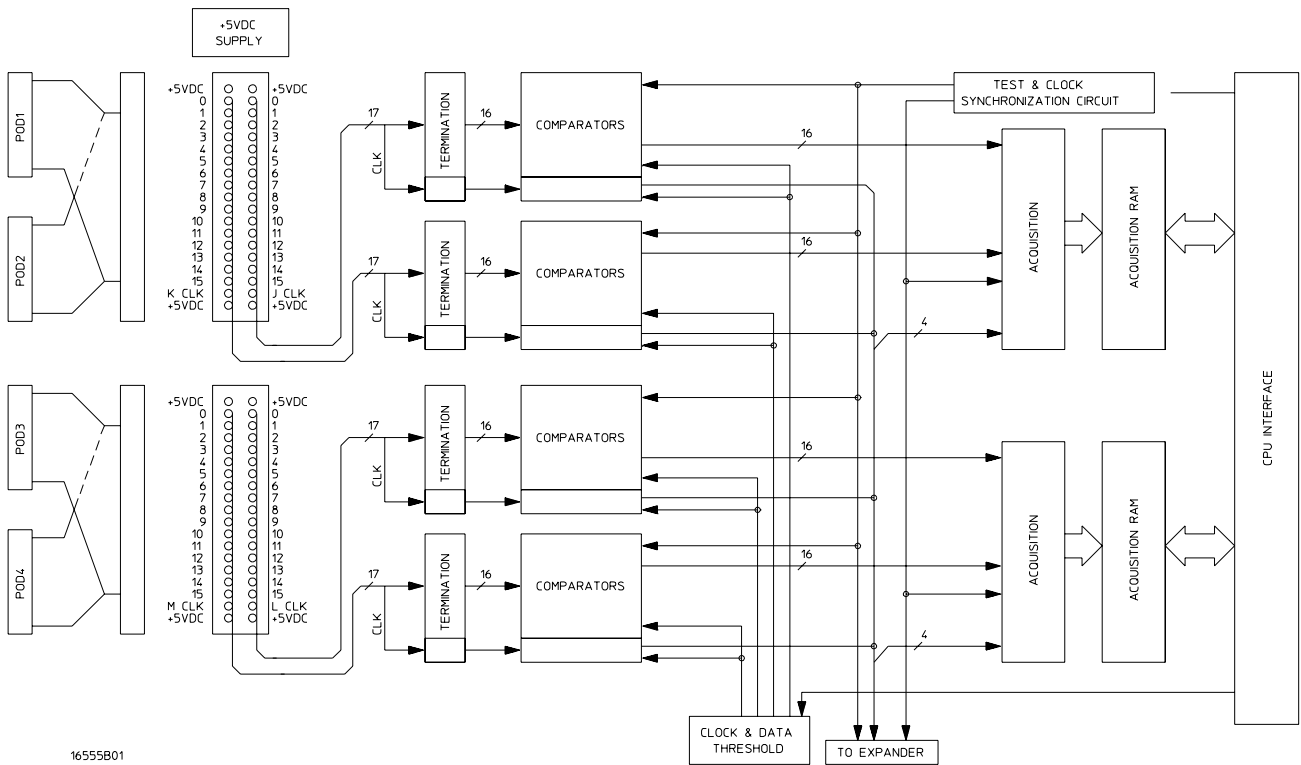

16555B01

**Probing.** The probing system consists of a tip network, a probe cable, and terminations which reside on the analyzer card. Each probe cable is made up of two woven cables, each one carrying 16 data channels and 1 clock/data channel. The four clock/data channels on each logic analyzer plus the 64 data channels on each logic analyzer card results in a maximum of 68 available data acquisition channels for each card.

Each channel of the probing system has its own ground. In addition the pod has a

single ground. For applications where many channels are used (greater than three) and signal risetimes are less than 3 ns, individual channel grounds should be used.

The probe tip networks comprise a series of resistors (250 Ohm) connected to a parallel combination of a 90 KOhm resistor and a 8.5 pF capacitor. The parallel 90 KOhm and 8.5 pF capacitor along with the lossy cable and terminations form a divide-by-ten probe system. The 250 Ohm tip resistor is used to buffer (or raise the impedance of) the 8.5 pF capacitor that is in series with the cable capacitance.

**Comparators.** Two 9-channel comparators interpret the incoming data and clock signals as either high or low, depending on where the user-programmable threshold is set. The threshold voltage of each pod is individually programmed, and the voltage selected applies to the clock channel as well as the data channels of each pod.

Each of the comparators has a serial test input port used for testing purposes. A test bit pattern is sent from the Test and Clock Synchronization Circuit to the comparators. The comparators then propagate the test signal on each of the nine channels of the comparator. Consequently, the operating system software can test all data and clock channel pipelines on the circuit board through the comparator.

**Acquisition.** Each acquisition circuit is made up of a single acquisition IC. Each acquisition IC is a 34-channel state/timing logic analyzer. Two acquisition ICs are included on every logic analyzer card for a total of 64 data channels and 4 clock/data channels. All of the sequencing, storage qualification, pattern/range recognition and event counting functions are performed by the acquisition IC.

Also, the acquisition ICs perform master clocking functions. All four state acquisition clocks are sent to each acquisition IC, and the acquisition ICs generate their own sample clocks. Every time the user selects RUN, the acquisition ICs individually perform a clock optimization before data is stored.

Clock optimization involves using programmable delays in the acquisition ICs to position the master clock transition where valid data is captured. This procedure greatly reduces the effects of channel-to-channel skew and other propagation delays.

In the timing acquisition mode, an oscillator-driven clock circuit provides a four-phase 125-MHz clock signal to each of the acquisition ICs. For high speed timing acquisition (125-MHz and faster), the four-phase 125-MHz clock signal determines the sample period. For slower sample rates, one of the two acquisition ICs divides the 125-MHz clock signal to the appropriate sample rate. The sample clock is then sent to the other acquisition ICs.

**Acquisition RAM.** The acquisition RAM is external to the acquisition IC. The acquisition RAM consists of 18 RAM ICs (256K x 16). A memory management

circuit controls RAM addressing during an acquisition run and during data upload to the mainframe CPU.

**Test and Clock Synchronization Circuit.** ECLinPS (ECL in pico seconds) ICs are used in the Test and Clock Synchronization Circuit for reliability and low channel-to-channel skew. Test patterns are generated and sent to the comparators during software operation verification (self-tests). The test patterns are propagated across all data and clock channels and read by the acquisition ICs to verify that the data and clock pipelines are operating correctly.

Also, the Test and Clock Synchronization Circuit generates a four-phase 125-MHz sample/synchronization signal for the acquisition ICs operating in the timing acquisition mode. At fast sample rates, the synchronizing signal keeps the internal clocking of the individual acquisition ICs locked in step with the other acquisition ICs in the module. At slower sample rates, one of the acquisition ICs divides the 125-MHz clock signal to the appropriate sample rate. The slow speed sample clock is then used by both acquisition ICs.

**Clock and Data Threshold.** The threshold circuit includes a precision octal DAC and precision op amp drivers. Each of the eight channels of the DAC is individually programmable which allows the user to set the thresholds of the individual pods. The 16 data channels and the clock/data channel of each pod are all set to the same threshold voltage.

**CPU Interface.** The CPU interface is a programmable logic device that converts the bus signals generated by the microprocessor on the mainframe CPU card into control signals for the logic analyzer card. All functions of the state and timing card can be controlled from the backplane of the mainframe system including storage qualification, sequencing, assigning clocks and qualifiers, RUN and STOP, and thresholds. Data transfer between the logic analyzer card and the mainframe CPU card is also accomplished through the CPU interface.

**+5 VDC supply.** The +5 VDC supply circuit supplies power to active logic analyzer accessories such as preprocessors. Thermistors on the +5 VDC supply lines and on the ground return line protect the logic analyzer and the active accessory from overcurrent conditions. When an overcurrent condition is sensed, the thermistors create an open that shuts off the current from the +5 VDC supply. After a reset time of approximately 1 minute, the thermistor closes the circuit and makes the supply current available.

### The 16740/41/42A logic analyzer as an expander

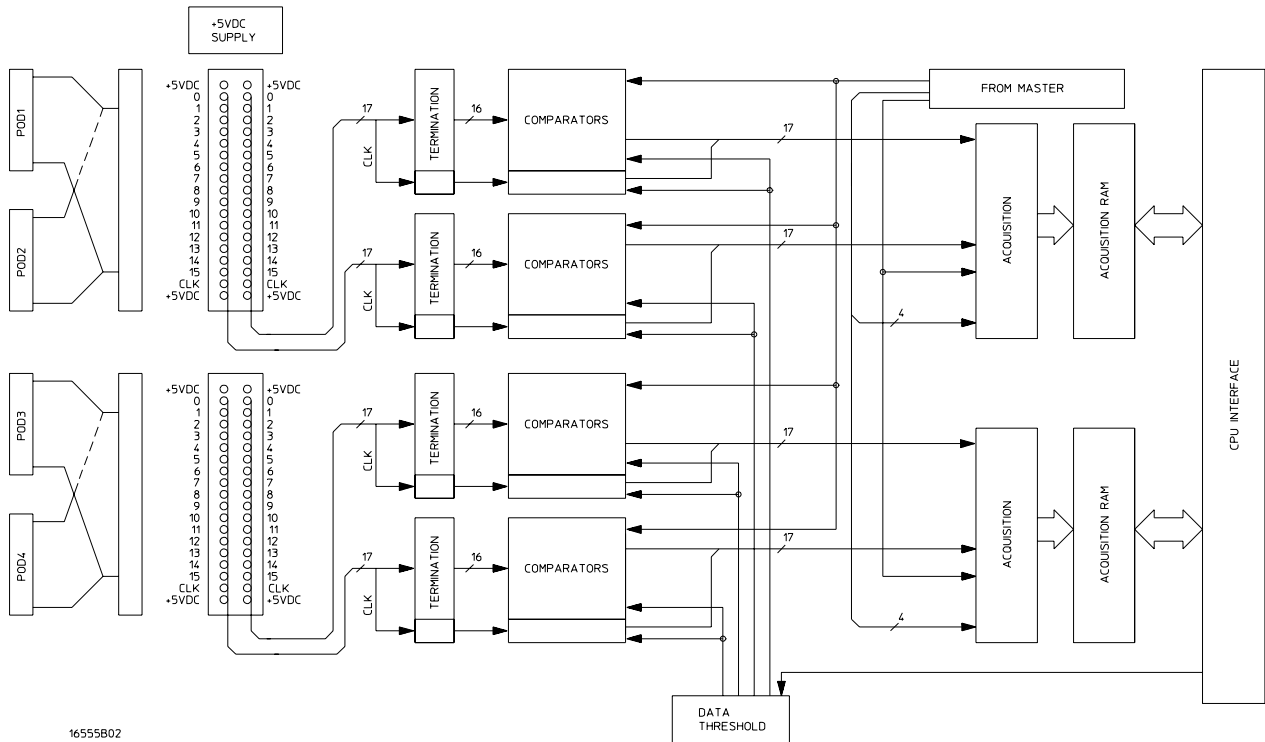

1655802

The logic analyzers can be connected together in multi-card master/expander configuration. All of the functions of the logic analyzer configured as a master are retained by the logic analyzer configured as an expander with a few exceptions. As a master and expander multi-card logic analyzer module, most of the supporting circuitry on the expander configured card is disabled to allow both the master and expander cards to operate together as one module with no compromise in functionality in 136-, 204-, 272-, or 340-channel configurations.

The same signals that drive the acquisition ICs on the master configured card also drive the acquisition ICs on the expander configured card.

**Acquisition.** The four clocks sent to the master card are also sent to the acquisition ICs on all expander cards. The acquisition ICs on the expander cards individually generate their own sample clock for the state acquisition mode. For timing acquisition mode, the master card also passes the synchronization signal to the expander cards.

The four clock/data lines on expander card pods are not available for either state mode clocking or state clock qualification. However, the four clock/data lines are still available as data channels.

**Test and Clock Synchronization Circuit.** The signals generated by the Test and Clock Synchronization Circuit of the master card are sent to all expander cards. Consequently, the Test and Clock Synchronization Circuit on each expander card is disabled to allow the master-configured card to drive the expander-configured card. The functionality of the Test and Clock Synchronization Circuit remains the same, but the circuit drives up to 8 more Acquisition IC and up to 16 more comparator test inputs.

**Threshold.** The thresholds of each of the expander card pods are individually programmable, as with the master card pods. The threshold of the data and clock/data channels of each pod is set to the same threshold voltage. The clock/data channel on each pod of the expander card is available only as a data channel.

---

## Self-Tests Description

The self-tests for the logic analyzer identify the correct operation of major functional areas in the module.

**CPLD Register Test.** The CPLD Register Test verifies that the 16700-series backplane can communicate with the 16740/41/42A module CDLP. The CPLD is used to configure the backplane and the memory devices. The test is done using both a walking “1” and walking “0” pattern. After the pattern has been stepped, internal device registers are read.

Passing the CPLD Registers Test implies that the module backplane device can be properly configured for module setup and data download.

**Load FPGA Test.** The Load FPGA Test verifies that the backplane interface device and the data memory control device can be configured. Configuration data is read from a file. During the configuration process, status signals are checked to verify the 16740/41/42A module hardware is operating properly during the configuration upload.

Passing the Load FPGA Test implies that the module can be properly configured for normal operation.

**FPGA Register Test.** The FPGA Register Test verifies that the read/write registers of the backplane interface device and the memory control device can be written to then read. Both a walking “1” and “0” pattern is written to the device registers. The registers are then read and compared with known values.

Passing the FPGA Registers Test implies that the module hardware configuration can be properly managed as part of normal module operation.

**Memory Data Bus Test.** The Memory Data Bus Test verifies the read/write access of the acquisition module from the system backplane. In addition, some of the operations of the acquisition memory and control are also tested. A walking

“1” and “0” is written to the first memory location. The contents of the first memory location is then downloaded and compared with known values.

Passing the Memory Data Bus Test implies that data stored in the acquisition memory can be uploaded from the 16740/41/42A module to the 16700-series system.

**Memory Address Bus Test.** The Memory Address Bus Test verifies the operation of the acquisition memory address bus. After initializing the acquisition memory, the address bus is exercised with a walking “1” and “0” pattern. At each resulting memory address, test data is stored. The test data is then downloaded and compared with known values.

Passing the Memory Address Bus Test implies that each signal line of the acquisition memory address bus is operational, and therefore all locations in the acquisition memory can be accessed.

**HW Assisted Memory Cell Test.** After verifying the acquisition memory address bus signal lines using the Memory Address Bus Test, the HW Assisted Memory Cell Test does a read/write test on every location in the acquisition memory. Each location in acquisition memory is filled with a test data pattern. After loading acquisition memory, the test data at each memory location is downloaded then compared with known values.

Passing the HW Assisted Memory Cell Test implies that each location in acquisition memory can be accessed, written, read, and can properly store data.

**Memory Unload Modes Test.** The Memory Unload Modes Test verifies the CPU interface can properly manage the acquisition memory unload in both full-channel, half-channel, and interleaved modes. Test data is written to acquisition memory. Different unload modes are selected, then the data is read and compared with known values.

Passing the Memory Unload Modes Test implies that the data can be reliably read from acquisition memory in full-channel, half-channel, or interleaved mode. This test along with the Memory Data Bus Test and Memory Address Bus Test provide complete testing of acquisition memory downloading through the CPU interface.

**Memory DMA Unload Test.** The Memory DMA Unload Test performs the same functions as the Memory Unload Test, except DMA backplane transfers are used to read the data from acquisition memory.

**Memory Sleep Mode Test.** The Memory Sleep Mode Test verifies the self refresh mode of acquisition memory devices. Memory self refresh mode is enabled when the memory control device is reprogrammed during normal operation.

Passing the Memory Sleep Mode Test verifies the acquisition memory will retain data during changes in 16740/41/42A operating modes during normal operation.

**Chip Registers Read/Write Test.** The Chip Registers Read/Write Test verifies that the registers of each acquisition IC are operating properly. Test patterns are written to each register on each acquisition IC, read, and compared with known values. The registers are reset, and verified that each register has been initialized. Test patterns are then written to ensure the chip address lines are not shorted or opened. Finally test data is written to registers of individual acquisition ICs to ensure each acquisition IC can be selected independently.

Passing the Chip Registers Read/Write Test implies that the acquisition IC registers can store acquisition control data to properly manage the operating of each IC.

**Analyzer Chip Memory Bus Test.** The Analyzer Chip Memory Bus Test verifies the operation of the acquisition memory buses between acquisition ICs. After initializing the memory a walking “1” and “0” pattern is created at the output of the acquisition ICs. This test data is stored in memory, read, and compared with known values.

Passing the Analyzer Chip Memory Bus Test implies that the acquisition memory buses between the acquisition ICs and acquisition memory is operating, and that acquisition data can propagate from the ICs to memory.

**System Clocks (Master/Slave/Psync) Test.** The System Clocks (Master/Slave/Psync) Test verifies the system clock are functional between all boards in a master/expander multi-card module. The module is configured for a simple measurement and test data is created. The test data is then downloaded and compared with known values.

Passing the System Clocks (Master/Slave/Psync) Test implies that the acquisition ICs of each expander board of a multi-card configuration can properly receive system clocks, and that all acquisition ICs in the multi-card module will properly capture data.

**Analyzer Memory Bus SU/H Measure.** The Analyzer Memory Bus SU/H Measure is an internal test that ensures the timing between the acquisition IC and acquisition memory is within acceptable parameters.

**System Backplane Clock Test.** The System Backplane Clock Test verifies the 100 MHz acquisition system clock. The test also ensures an on-board phase-locked loop can properly generate multiples of the acquisition system clock frequency. The 100 MHz acquisition system clock is first routed directly to the acquisition ICs. A timer is initialized, run, and stopped after 100ms. the counter is read, and compared with a known value. The acquisition system clock is then routed to the phase-locked loop to generate a frequency of 166.7 MHz. Again, the counter is initialized, run, and stopped after 100ms. The counter is read, and compared with a known value.

Passing the System Backplane Clock Test implies that the system acquisition clock is operating, and is within 5% of the desired acquisition frequency. Note



that the procedure to test the Time Interval Accuracy in Chapter 3 provides a more reliable characterization of clock oscillator drift.

**Comparators Test.** The Comparators Test ensures the data signal comparators in the module front end can be set to their maximum and minimum thresholds, and that they recognize activity at the signal inputs. A clock signal is routed to a test port on each comparator. The threshold is then set to the minimum value. The comparator output is then read, and compared with a known value. The threshold is then set to a maximum value. The comparator output is again read, and compared with a known value.

Passing the Comparators Test implies that the front end comparators are operating properly, can recognize both a logic “0” and logic “1”, and can properly send the acquisition data downstream to the acquisition ICs.

**Inter-chip Resource Bus Test.** The Inter-chip Resource Bus Test verifies the resource lines that run between each acquisition IC to ensure that the resource lines can be both driven as outputs and read as inputs. The resource registers are written with test patterns, read back, then compared with known values. The resource registers are then written with test patterns, read back from a different acquisition IC, and then compared with known values.

**Inter-module Flag Bits Test.** Flag bits are used for module-to-module communication within the 16700-series system. The Inter-module Flag Bits Test verifies that the flag bit lines can be driven and received by each acquisition IC in each module. Test patterns are written to the flag registers, read by the other acquisition ICs in the other modules, and then compared with known values.

Passing the Inter-module Flag Bits Test implies that the acquisition ICs can communicate using Flag Bits through the CPU interface and the 16700-series backplane, and that the operations utilizing the flag bits can be properly recognized by all modules in the system.

**Global and Local Arm Lines Test.** The Global and Local Arm Lines Test verifies that the local arm signal can be received by each acquisition IC on the master board. The test also verifies the global arm signal can be driven by each acquisition IC on a master board, and received by all acquisition ICs in the module on the master and on all expander boards. The arm lines are asserted and read at the acquisition ICs to ensure each acquisition IC recognizes the signal.

Passing the Global and Local Arm Lines Test implies any acquisition ICs on the master board can arm the module, and that all acquisition ICs can recognize the arm signal.

**Calibration Test.** The Calibration Test ensures that each acquisition IC in the module can perform an operational accuracy self-calibration every time Run is selected. The module is set in various configurations, after which the self-calibration routine is initiated. The results of the self-calibration is then checked

to see if self-calibration was successful.

Passing the Calibration Test implies that the module can reliably perform an operation accuracy self-calibration every time Run is selected. Consequently the incoming data is optimized to reduce channel-to-channel skew so the acquisition ICs can reliably capture the incoming data.

**Zoom Data Lines Test.** The Zoom Data Lines Test verifies the 2GHz TimingZoom controller data path. A test pattern is written to a counter register in the zoom controller. The counter register is decremented using a system clock while counting each system clock pulse. When the register reaches “0”, the register decrement is halted. The system clock count is then compared with the initial register data pattern. This process is repeated for a number of register test patterns.

Passing the Zoom Data Lines Test implies that the counter register in the zoom controller can be written to, and that the data path to the zoom controller is reliable.

**Zoom Master Controller Test.** The Zoom Master Controller Test verifies the zoom controller circuit on the master board. The test is similar to the Zoom Controller Data Lines Test, except a divider ratio is configured to decrement the counter register a number of times for each system clock pulse.

Passing the Zoom Master Controller Test implies that the 2GHz TimingZoom controller on the master board is operating properly.

**Zoom FISO Redundancy Test.** The Zoom FISO Redundancy Test verifies the 2GHz TimingZoom acquisition memory. The FISOs are put into a self-test mode, which clocks test patterns into FISO memory. The FISO memory is then downloaded and compared with known values. Additionally, if bad memory locations are found, a redundancy routine is initiated to replace bad memory locations with a redundant memory location.

Passing the Zoom FISO Redundancy Test implies each memory location in the 2GHz TimingZoom acquisition memory can store a logic “0” and logic “1”.

**Zoom Acquisition Test.** The Zoom Acquisition Test verifies the data inputs to the 2GHz TimingZoom acquisition memory and that the TimingZoom acquisition clock is at the correct sampling frequency. Test data is created by clocking the comparators test port. A TimingZoom acquisition is made, and 16k samples downloaded. The patterns are compared with known values. Additionally, data transition edges are counted and compared with a known value.

Passing the Zoom Acquisition Test implies that the 2GHz Timing Zoom circuit is operating properly, and that a TimingZoom acquisition reliably captures acquisition data.

**Zoom Chip Select Test.** The Zoom Chip Select Test verifies that each of the 2GHz TimingZoom memory ICs are individually selectable for data upload. Test data is acquired and stored in the TimingZoom FISO memory. The test data is then uploaded from each FISO memory IC and compared with known good data.

Passing the Zoom Chip Select Test implies that each TimingZoom memory IC is individually addressable to upload TimingZoom data.



## **Symbols**

+5 VDC supply, 156

## **Numerics**

0 V user threshold, 46

## **A**

accessories, 10  
acquisition, 155, 157  
acquisition RAM, 155  
analyzer  
  connect, 42, 53, 71, 102, 110  
  set up, 41, 48, 67, 84, 88, 99, 106  
assemblies  
  exchange, 148  
  return, 145

## **B**

block-level theory, 154

## **C**

cable  
  replace probe, 144  
  test, 133  
calibrating  
  see also testing performance  
  calibration, 125–126  
  strategy, 126  
  test, 161  
characteristics, 12  
  environmental, 12  
chip registers, 161  
circuit board  
  replace, 142  
clean module, 29  
clock and data threshold, 156  
comparators, 155, 161  
configure  
  multi-card module, 20  
  one-card module, 18  
CPLD register, 158  
CPU interface, 156

## **D**

data threshold, 156

## **E**

ECL threshold, 43  
environment  
  characteristics, 12

operating, 16  
equipment  
  set up, 38, 40, 48, 66, 83, 98, 105  
  test, 13, 32  
exchange assemblies, 148  
exit test system, 132

## **F**

features, 2  
flowcharts, 128  
FPGA  
  load test, 158  
  register test, 158

## **G**

general information, 9  
global arm lines, 161

## **I**

install module, 26  
instrument warm-up, 32  
inter-chip resource bus, 161  
inter-module flag bits, 161

## **L**

local arm lines, 161

## **M**

mainframe, 10  
  operating system, 128  
  prepare, 17  
memory  
  address bus test, 159  
  analyzer bus SU/H measure, 160  
  analyzer chip bus test, 160  
  data bus test, 158  
  DMA unload test, 159  
  HW assisted cell test, 159  
  sleep mode test, 159  
  unload modes test, 159  
module  
  clean, 29  
  inspect, 16  
  install, 26  
  remove, 140  
  replace, 143  
  test, 28  
multi-card module, 20  
  configure, 20  
  test, 32, 105

multiple-clock, multiple-edge, state  
  acquisition, 66–82

## **O**

one-card module  
  configure, 18  
  test, 32  
operating  
  environment, 16  
  system, 10, 128

## **P**

parts  
  ordering, 148  
  replaceable, 149  
performance test record, 121  
power  
  requirements, 16  
  system, 28  
  test, 33  
  test auxiliary, 138  
preparing for use, 15–29  
probing, 154

## **R**

replace  
  circuit board, 142  
  module, 143  
  probe cable, 144  
replaceable parts, 147–151  
replacing assemblies, 139–146  
return assemblies, 145

## **S**

self-test, 33, 34, 131  
  description, 158  
  setup/hold, 58, 76, 93, 115  
single-clock, multiple-edge, state  
  acquisition, 83–97  
single-clock, single-edge, state  
  acquisition, 48–65  
specifications, 11  
storage, 16  
system  
  backplane clock, 160  
  operating, 10, 128  
  test, 132  
  turn on, 28

## T

### test

- 0V user threshold, 46
- analyzer chip memory bus, 160
- analyzer memory bus SU/H measure, 160
- cables, 133
- calibration, 161
- chip registers, 160
- comparators, 161
- connectors, 35
- CPLD register, 158
- ECL threshold, 43
- equipment, 13, 32, 38
- FPGA load, 158
- FPGA register, 158
- global and local arm lines, 161
- HW assisted memory cell, 159
- inter-chip resource bus, 161
- inter-module flag bits, 161
- interval, 32
- master controller, 162
- memory address bus, 159
- memory data bus, 158
- memory DMA unload, 159
- memory sleep mode, 159
- memory unload modes, 159
- module, 28
- multi-card module, 32, 105
- multiple-clock, multiple-edge, state acquisition, 66
- one-card module, 32
- performance record, 121
- pod, 47
- power, 33, 138
- record description, 32
- self-test, 33, 131
- single-clock, multiple-edge, state acquisition, 83
- single-clock, single-edge, state acquisition, 48
- strategy, 32
- system, 132
- system backplane clock, 160
- system clocks, 160
- threshold accuracy, 40
- time interval accuracy, 98
- zoom acquisition, 162
- zoom data lines, 162
- zoom FISO redundancy, 162

test and clock synchronization circuit, 156, 158

- test signal, 56, 74, 91, 113
- testing performance, 31
  - equipment, 13, 32, 38
  - interval, 32
  - multi-card module, 32, 105
  - multiple-clock, multiple-edge, state acquisition, 66
  - single-clock, multiple-edge, state acquisition, 83
  - single-clock, single-edge, state acquisition, 48
  - threshold accuracy, 40
  - time interval accuracy, 98
- theory of operation, 153
- threshold, 158
  - 0V user, 46
  - accuracy, 40
  - data, 156
  - ECL, 43
- time interval accuracy, 98
- tools required, 140
- troubleshooting, 127

## V

- VRAM
  - parallel data bus, 161

## Z

- zoom
  - acquisition, 162
  - controller data lines, 162
  - FISO redundancy, 162
  - master controller, 162

Reproduction, adaptation, or translation without prior written permission is prohibited, except as allowed under the copyright laws.

#### Restricted Rights Legend.

Use, duplication or disclosure by the U.S. Government is subject to restrictions as set forth in subparagraph (c) (1) (ii) of the Rights in Technical Data and Computer Software clause at DFARS 252.227-7013 for DOD agencies, and subparagraphs (c) (1) and (c) (2) of the Commercial Computer Software Restricted Rights clause at FAR 52.227-19 for other agencies.

Agilent Technologies  
3000 Hanover Street  
Palo Alto, California 94304  
U.S.A.

#### Document Warranty

The information contained in this document is subject to change without notice.

**Agilent Technologies makes no warranty of any kind with regard to this material, including, but not limited to, the implied warranties of merchantability or fitness for a particular purpose.**

Agilent Technologies shall not be liable for errors contained herein or for damages in connection with the furnishing, performance, or use of this material.

#### Safety

This apparatus has been designed and tested in accordance with IEC Publication 1010, Safety Requirements for Measuring Apparatus, and has been supplied in a safe condition. This is a Safety Class I instrument (provided with terminal for protective earthing). Before applying power, verify that the correct safety precautions are taken (see the following warnings). In addition, note the external markings on the instrument that are described under "Safety Symbols."

#### Warning

- Before turning on the instrument, you must connect the protective earth terminal of the instrument to the protective conductor of the (mains) power cord. The mains plug shall only be inserted in a socket outlet provided with a protective earth contact. You must not negate the protective action by using an extension cord (power cable) without a protective conductor (grounding). Grounding one conductor of a two-conductor outlet is not sufficient protection.

- Only fuses with the required rated current, voltage, and specified type (normal blow, time delay, etc.) should be used. Do not use repaired fuses or short-circuited fuseholders. To do so could cause a shock or fire hazard.

- Service instructions are for trained service personnel. To avoid dangerous electric shock, do not perform any service unless qualified to do so. Do not attempt internal service or adjustment unless another person, capable of rendering first aid and resuscitation, is present.

- If you energize this instrument by an auto transformer (for voltage reduction), make sure the common terminal is connected to the earth terminal of the power source.

- Whenever it is likely that the ground protection is impaired, you must make the instrument inoperative and secure it against any unintended operation.

- Do not operate the instrument in the presence of flammable gasses or fumes.

Operation of any electrical instrument in such an environment constitutes a definite safety hazard.

- Do not install substitute parts or perform any unauthorized modification to the instrument.

- Capacitors inside the instrument may retain a charge even if the instrument is disconnected from its source of supply.

#### Safety Symbols



Instruction manual symbol: the product is marked with this symbol when it is necessary for you to refer to the instruction manual in order to protect against damage to the product.



Hazardous voltage symbol.



Earth terminal symbol: Used to indicate a circuit common connected to grounded chassis.

#### WARNING

The Warning sign denotes a hazard. It calls attention to a procedure, practice, or the like, which, if not correctly performed or adhered to, could result in personal injury. Do not proceed beyond a Warning sign until the indicated conditions are fully understood and met.

#### CAUTION

The Caution sign denotes a hazard. It calls attention to an operating procedure, practice, or the like, which, if not correctly performed or adhered to, could result in damage to or destruction of part or all of the product. Do not proceed beyond a Caution symbol until the indicated conditions are fully understood or met.

---

**Product Warranty**

This Agilent Technologies product has a warranty against defects in material and workmanship for a period of one year from date of shipment. During the warranty period, Agilent Technologies will, at its option, either repair or replace products that prove to be defective.

For warranty service or repair, this product must be returned to a service facility designated by Agilent Technologies.

For products returned to Agilent Technologies for warranty service, the Buyer shall prepay shipping charges to Agilent Technologies and Agilent Technologies shall pay shipping charges to return the product to the Buyer. However, the Buyer shall pay all shipping charges, duties, and taxes for products returned to Agilent Technologies from another country.

Agilent Technologies warrants that its software and firmware designated by Agilent Technologies for use with an instrument will execute its programming instructions when properly installed on that instrument. Agilent Technologies does not warrant that the operation of the instrument software, or firmware will be uninterrupted or error free.

**Limitation of Warranty**

The foregoing warranty shall not apply to defects resulting from improper or inadequate maintenance by the Buyer, Buyer-supplied software or interfacing, unauthorized modification or misuse, operation outside of the environmental specifications for the product, or improper site preparation or maintenance.

**No other warranty is expressed or implied. Agilent Technologies specifically disclaims the implied warranties of merchantability or fitness for a particular purpose.**

**Exclusive Remedies**

The remedies provided herein are the buyer's sole and exclusive remedies. Agilent Technologies shall not be liable for any direct, indirect, special, incidental, or consequential damages, whether based on contract, tort, or any other legal theory.

**Assistance**

Product maintenance agreements and other customer assistance agreements are available for Agilent Technologies products. For any assistance, contact your nearest Agilent Technologies Sales Office.

**Certification**

Agilent Technologies certifies that this product met its published specifications at the time of shipment from the factory. Agilent Technologies further certifies that its calibration measurements are traceable to the United States National Institute of Standards and Technology, to the extent allowed by the Institute's calibration facility, and to the calibration facilities of other International Standards Organization members.

**About this edition**

This is the *Agilent Technologies 16740/41/42A Logic Analyzer*.

Publication number  
16740-97000, December 2001  
Printed in USA.

New editions are complete revisions of the manual. Many product updates do not require manual changes; and, conversely, manual corrections may be done without accompanying product changes. Therefore, do not expect a one-to-one correspondence between product updates and manual updates.